

HYMAX CLAMP®

(1.5"-26")

HYMAX®
Repair the past. Connect the future.

PRODUCT SPECIFICATIONS

NOTE: Pictures and drawings reflect HYMAX Clamp sizes 1.5"-12".
Sizes 14"-26" have two closing mechanisms.

FEATURES

- EASY TO INSTALL – STARTING WITH ONLY 2 BOLTS
- STAINLESS STEEL, LIGHTWEIGHT MONOBLOCK DESIGN
- WIDE-RANGE, REPLACES UP TO 3 STANDARD PRODUCTS
- STRONG AND ANTI-CORROSION RESISTANT
- SUITABLE FOR ALL PIPE TYPES
- DURABLE EPDM GASKET

SPECIFICATIONS

STANDARDS

ALL PRODUCTS MEET OR EXCEED STANDARDS AWWA C230, NSF-61 AND NSF-372.

STANDARDS

AVAILABLE IN NOMINAL DIAMETER FROM 1.5"-26":

6" LENGTH – 1.5"-12" ND.

9" LENGTH – 1.5"-12" ND.

12" LENGTH – 1.5"-26" ND.

15" LENGTH – 4"-26" ND.

24" LENGTH – 4"-26" ND.

MATERIALS

BODY

AISI 304 STAINLESS STEEL.

PRESSURE-ASSISTED GASKET

EPDM COMPOUNDED FOR WATER AND SEWERAGE. MEETS NSF-61 AND NSF-372 FOR CONTACT WITH DRINKING WATER.

GASKET BRIDGE

AISI 304 STAINLESS STEEL.

COMPRESSION BEAM

AISI 304/304L CASTING (ASTM-A351-CF8).

ADJUSTING PIN

AISI 304/304L CASTING (ASTM-A351-CF8).

LUGS

POLYCARBONATE.

NUTS AND BOLTS

AISI 304 STAINLESS STEEL. ROLLED THREAD AND ZINC-BASED ANTI-GALLING COATING.

PRODUCT PERFORMANCE (※)

WORKING TEMPERATURE -20°F UP TO +180°F

WORKING PRESSURE Option 1 -150 PSI
Option 2 - 200 PSI

RATED PRESSURE Option 1 - 225 PSI
Option 2 - 300 PSI

※ CONTACT KRAUSZ FOR DETAILS.

PRODUCT TABLES

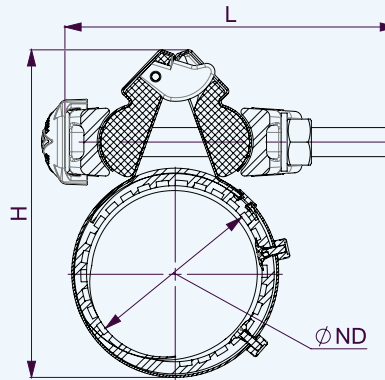

HYMAX CLAMP LENGTH 6" (1.5"-12")

Krausz Part Number	ND (inch)	Overall Range (inch)	Bolts Qty.-Size (inch)	Bolts Length L (inch)	H (inch)	Option 1			Option 2			Approx Weight (Lbs)
						Working Pressure (psi)	Rated Pressure (psi)	Torque (Ft-Lbs)	Working Pressure (psi)	Rated Pressure (psi)	Torque (Ft-Lbs)	
267-56-0047-10	1.5	1.86-2.16	2-M12	5.31	4.56	150	225	30	200	300	40	3.63
267-56-0059-10	2	2.35-2.65	2-M12	5.31	5.31	150	225	30	200	300	40	4.05
267-56-0072-10	2.5	2.85-3.15	2-M12	5.31	5.78	150	225	30	200	300	40	4.16
271-56-0087-10W	3	3.42-4.25	2-M14	7	7	150	225	40	200	300	55	6.71
271-56-0113-10W	4	4.47-5.27	2-M14	7	8	150	225	50	200	300	65	7.018
271-56-0122-10W		4.80-5.60	2-M14	7	8.5	150	225	50	200	300	65	7.172
271-56-0139-10W	6	5.50-6.30	2-M14	7	9.2	150	225	60	200	300	80	7.414
271-56-0167-10W		6.60-7.40	2-M14	7	10.3	150	225	60	200	300	80	7.81
271-56-0174-10W		6.84-7.64	2-M14	7	10.6	150	225	60	200	300	80	7.942
271-56-0198-10W	8	7.80-8.60	2-M14	7	11.5	150	225	70	200	300	90	8.756
271-56-0218-10W		8.60-9.40	2-M14	7	12.4	150	225	70	200	300	90	9.086
271-56-0228-10W		9.00-9.80	2-M14	7	12.8	150	225	70	200	300	90	9.306
271-56-0272-10W	10	10.73-11.53	2-M14	8.27	14.6	150	225	100	200	300	130	10.89
271-56-0288-10W		11.35-12.15	2-M14	8.27	15.2	150	225	100	200	300	130	11.396
271-56-0323-10W	12	12.75-13.55	2-M16	8.27	16.7	150	225	100	200	300	130	14.146
271-56-0345-10W		13.60-14.40	2-M16	8.27	17.5	150	225	100	200	300	130	14.652

HYMAX CLAMP LENGTH 9" (1.5"-12")

Krausz Part Number	ND (inch)	Overall Range (inch)	Bolts Qty.-Size (inch)	Bolts Length L (inch)	H (inch)	Option 1			Option 2			Approx Weight (Lbs)
						Working Pressure (psi)	Rated Pressure (psi)	Torque (Ft-Lbs)	Working Pressure (psi)	Rated Pressure (psi)	Torque (Ft-Lbs)	
268-56-0047-10	1.5	1.86-2.16	2-M12	5.31	4.56	150	225	45	200	300	60	5.92
268-56-0059-10	2	2.35-2.65	2-M12	5.31	5.31	150	225	45	200	300	60	6.57
268-56-0072-10	2.5	2.85-3.15	2-M12	5.31	5.78	150	225	45	200	300	60	6.64
272-56-0087-10W	3	3.42-4.25	2-M14	7	7	150	225	70	200	300	90	10.74
272-56-0113-10W	4	4.47-5.27	2-M14	7	8	150	225	75	200	300	100	11.26
272-56-0122-10W		4.80-5.60	2-M14	7	8.5	150	225	75	200	300	100	11.55
272-56-0139-10W	6	5.50-6.30	2-M14	7	9.2	150	225	80	200	300	105	11.92
272-56-0167-10W		6.60-7.40	2-M14	7	10.3	150	225	80	200	300	105	12.52
272-56-0174-10W		6.84-7.64	2-M14	7	10.6	150	225	80	200	300	105	12.72
272-56-0198-10W	8	7.80-8.60	2-M14	7	11.5	150	225	95	200	300	125	13.97
272-56-0218-10W		8.60-9.40	2-M14	7	12.4	150	225	95	200	300	125	14.5
272-56-0228-10W		9.00-9.80	2-M14	7	12.8	150	225	95	200	300	125	14.76
272-56-0272-10W	10	10.73-11.53	2-M14	8.27	14.6	150	225	135	200	300	175	17.23
272-56-0288-10W		11.35-12.15	2-M14	8.27	15.2	150	225	135	200	300	175	17.71
272-56-0323-10W	12	12.75-13.55	2-M16	9.45	16.7	150	225	150	200	300	195	21.82
272-56-0345-10W		13.60-14.40	2-M16	9.45	17.5	150	225	150	200	300	195	22.62

HYMAX CLAMP LENGTH 12" (1.5"-12")

Krausz Part Number	ND (inch)	Overall Range (inch)	Bolts Qty.-Size (inch)	Bolts Length L (inch)	H (inch)	Option 1			Option 2			Approx Weight (Lbs)
						Working Pressure (psi)	Rated Pressure (psi)	Torque (Ft-Lbs)	Working Pressure (psi)	Rated Pressure (psi)	Torque (Ft-Lbs)	
269-56-0047-10	1.5	1.86-2.16	2-M12	5.31	4.56	150	225	45	200	300	60	7.94
269-56-0059-10	2	2.35-2.65	2-M12	5.31	5.31	150	225	45	200	300	60	8.75
269-56-0072-10	2.5	2.85-3.15	2-M12	5.31	5.78	150	225	45	200	300	60	8.99
273-56-0087-10W	3	3.42-4.25	2-M14	8.27	7	150	225	70	200	300	90	10.82
273-56-0113-10W	4	4.47-5.27	2-M14	8.27	8	150	225	75	200	300	100	11.09
273-56-0122-10W		4.80-5.60	2-M14	8.27	8.5	150	225	75	200	300	100	11.35
273-56-0139-10W	6	5.50-6.30	2-M14	8.27	9.2	150	225	80	200	300	105	11.79
273-56-0167-10W		6.60-7.40	2-M14	8.27	10.3	150	225	80	200	300	105	12.72
273-56-0174-10W		6.84-7.64	2-M14	8.27	10.6	150	225	80	200	300	105	13.16
273-56-0198-10W	8	7.80-8.60	2-M14	8.27	11.5	150	225	95	200	300	125	14.59
273-56-0218-10W		8.60-9.40	2-M14	8.27	12.4	150	225	95	200	300	125	15.29
273-56-0228-10W		9.00-9.80	2-M14	8.27	12.8	150	225	95	200	300	125	15.69
273-56-0272-10W	10	10.73-11.53	2-M14	8.27	14.6	150	225	135	200	300	175	18.96
273-56-0288-10W		11.35-12.15	2-M14	8.27	15.2	150	225	135	200	300	175	19.62
273-56-0323-10W	12	12.75-13.55	2-M16	9.45	16.7	150	225	150	200	300	195	25.01
273-56-0345-10W		13.60-14.40	2-M16	9.45	17.5	150	225	150	200	300	195	26.05

HYMAX CLAMP LENGTH 12" (12"-26")

Krausz Part Number	ND (inch)	Overall Range (inch)	Bolts Qty.-Size (inch)	Torque (Ft-Lbs)	Working Pressure (psi)
223-56-0346-10	12/14	13.64-15.24	8-M16	105	150
223-56-0361-10	14	14.20-15.80	8-M16	105	150
223-56-0398-10	14	15.68-17.28	8-M16	105	150
223-56-0415-10	16	16.33-17.93	8-M16	105	150
223-56-0450-10	16/18	17.72-19.32	8-M16	105	150
223-56-0469-10	16/18	18.48-20.08	8-M16	105	150
223-56-0505-10	18	19.88-21.48	8-M16	105	150
223-56-0521-10	18/20	20.50-22.10	8-M16	105	150
223-56-0530-10	18/20	20.87-22.47	8-M16	105	150
223-56-0559-10	20	22.00-23.60	8-M16	105	150
223-56-0575-10	20	22.65-24.25	8-M16	105	150
223-56-0592-10	20/24	23.30-24.90	8-M16	105	150
223-56-0610-10	20/24	24.00-25.60	8-M16	105	150
223-56-0627-10	24	24.68-26.28	8-M16	105	150
223-56-0649-10	24	25.54-27.14	8-M16	105	150
223-56-0663-10	24/26	26.10-27.70	8-M16	105	150
223-56-0684-10	24/26	26.93-28.53	8-M16	105	150
223-56-0706-10	24/26	27.80-29.40	8-M16	105	150

HYMAX CLAMP LENGTH 15" (4"-12")

Krausz Part Number	ND (inch)	Overall Range (inch)	Bolts Qty.-Size (inch)	Bolts Length L (inch)	H (inch)	Option 1			Option 2			Approx Weight (Lbs)
						Working Pressure (psi)	Rated Pressure (psi)	Torque (Ft-Lbs)	Working Pressure (psi)	Rated Pressure (psi)	Torque (Ft-Lbs)	
274-56-0113-10W	4	4.47-5.27	3-M14	8.27	8	150	225	75	200	300	100	18.83
274-56-0122-10W		4.80-5.60	3-M14	8.27	8.5	150	225	75	200	300	100	19.16
274-56-0139-10W	6	5.50-6.30	3-M14	8.27	9.2	150	225	80	200	300	105	19.78
274-56-0167-10W		6.60-7.40	3-M14	8.27	10.3	150	225	80	200	300	105	20.85
274-56-0174-10W		6.84-7.64	3-M14	8.27	10.6	150	225	80	200	300	105	21.14
274-56-0198-10W	8	7.80-8.60	3-M14	8.27	11.5	150	225	95	200	300	125	23.21
274-56-0218-10W		8.60-9.40	3-M14	8.27	12.4	150	225	95	200	300	125	24.07
274-56-0228-10W		9.00-9.80	3-M14	8.27	12.8	150	225	95	200	300	125	24.6
274-56-0272-10W	10	10.73-11.53	3-M14	8.27	14.6	150	225	135	200	300	175	28.66
274-56-0288-10W		11.35-12.15	3-M14	8.27	15.2	150	225	135	200	300	175	29.5
274-56-0323-10W	12	12.75-13.55	3-M16	9.45	16.7	150	225	150	200	300	195	36.38
274-56-0345-10W		13.60-14.40	3-M16	9.45	17.5	150	225	150	200	300	195	37.66

HYMAX CLAMP LENGTH 15" (12"-26")

Krausz Part Number	ND (inch)	Overall Range (inch)	Bolts Qty.-Size (inch)	Torque (Ft-Lbs)	Working Pressure (psi)
224-56-0346-10	12/14	13.64-15.24	10-M16	105	150
224-56-0361-10	14	14.20-15.80	10-M16	105	150
224-56-0398-10	14	15.68-17.28	10-M16	105	150
224-56-0415-10	16	16.33-17.93	10-M16	105	150
224-56-0450-10	16/18	17.72-19.32	10-M16	105	150
224-56-0469-10	16/18	18.48-20.08	10-M16	105	150
224-56-0505-10	18	19.88-21.48	10-M16	105	150
224-56-0521-10	18/20	20.50-22.10	10-M16	105	150
224-56-0530-10	18/20	20.87-22.47	10-M16	105	150
224-56-0559-10	20	22.00-23.60	10-M16	105	150
224-56-0575-10	20	22.65-24.25	10-M16	105	150
224-56-0592-10	20/24	23.30-24.90	10-M16	105	150
224-56-0610-10	20/24	24.00-25.60	10-M16	105	150
224-56-0627-10	24	24.68-26.28	10-M16	105	150
224-56-0649-10	24	25.54-27.14	10-M16	105	150
224-56-0663-10	24/26	26.10-27.70	10-M16	105	150
224-56-0684-10	24/26	26.93-28.53	10-M16	105	150
224-56-0706-10	24/26	27.80-29.40	10-M16	105	150

HYMAX CLAMP LENGTH 24" (4"-12")

Krausz Part Number	ND (inch)	Overall Range (inch)	Bolts Qty.-Size (inch)	Bolts Length L (inch)	H (inch)	Option 1			Option 2			Approx Weight (Lbs)
						Working Pressure (psi)	Rated Pressure (psi)	Torque (Ft-Lbs)	Working Pressure (psi)	Rated Pressure (psi)	Torque (Ft-Lbs)	
277-56-0113-10W	4	4.47-5.27	4-M14	8.27	8	150	225	75	200	300	100	27.71
277-56-0122-10W		4.80-5.60	4-M14	8.27	8.5	150	225	75	200	300	100	28.26
277-56-0139-10W	6	5.50-6.30	4-M14	8.27	9.2	150	225	80	200	300	105	29.25
277-56-0167-10W		6.60-7.40	4-M14	8.27	10.3	150	225	80	200	300	105	30.97
277-56-0174-10W		6.84-7.64	4-M14	8.27	10.6	150	225	80	200	300	105	31.39
277-56-0198-10W	8	7.80-8.60	4-M14	8.27	11.5	150	225	95	200	300	125	34.67
277-56-0218-10W		8.60-9.40	4-M14	8.27	12.4	150	225	95	200	300	125	36.04
277-56-0228-10W		9.00-9.80	4-M14	8.27	12.8	150	225	95	200	300	125	36.91
277-56-0272-10W	10	10.73-11.53	4-M14	8.27	14.6	150	225	135	200	300	175	44.02
277-56-0288-10W		11.35-12.15	4-M14	8.27	15.2	150	225	135	200	300	175	45.32
277-56-0323-10W	12	12.75-13.55	4-M16	9.45	16.7	150	225	150	200	300	195	54.76
277-56-0345-10W		13.60-14.40	4-M16	9.45	17.5	150	225	150	200	300	195	56.79

HYMAX CLAMP LENGTH 24" (12"-26")

Krausz Part Number	ND (inch)	Overall Range (inch)	Bolts Qty.-Size (inch)	Torque (Ft-Lbs)	Working Pressure (psi)
227-56-0346-10	12/14	13.64-15.24	16-M16	105	150
227-56-0361-10	14	14.20-15.80	16-M16	105	150
227-56-0398-10	14	15.68-17.28	16-M16	105	150
227-56-0415-10	16	16.33-17.93	16-M16	105	150
227-56-0450-10	16/18	17.72-19.32	16-M16	105	150
227-56-0469-10	16/18	18.48-20.08	16-M16	105	150
227-56-0505-10	18	19.88-21.48	16-M16	105	150
227-56-0521-10	18/20	20.50-22.10	16-M16	105	150
227-56-0530-10	18/20	20.87-22.47	16-M16	105	150
227-56-0559-10	20	22.00-23.60	16-M16	105	150
227-56-0575-10	20	22.65-24.25	16-M16	105	150
227-56-0592-10	20/24	23.30-24.90	16-M16	105	150
227-56-0610-10	20/24	24.00-25.60	16-M16	105	150
227-56-0627-10	24	24.68-26.28	16-M16	105	150
227-56-0649-10	24	25.54-27.14	16-M16	105	150
227-56-0663-10	24/26	26.10-27.70	16-M16	105	150
227-56-0684-10	24/26	26.93-28.53	16-M16	105	150
227-56-0706-10	24/26	27.80-29.40	16-M16	105	150