

# HYMAX GRIP<sup>®</sup> (1.5" - 12")

**HYMAX GRIP<sup>®</sup> RESTRAINT COUPLING**

---

**HYMAX GRIP<sup>®</sup> FLANGE ADAPTOR**

---

**HYMAX GRIP<sup>®</sup> CATHODIC AND CATHODIC F/A**

---

**HYMAX GRIP<sup>®</sup> REDUCER**

---

**HYMAX GRIP<sup>®</sup> END CAP**

---

**HYMAX GRIP<sup>®</sup> ELBOW 90° and 45°**

---

**HYMAX GRIP<sup>®</sup> SWIVELJOINT**



## WARNING



**CAUTION: THIS PRODUCT IS NOT INTENDED FOR USE ON NATURAL GAS PIPING, OR ANY OTHER TYPE OF GAS PIPING. THIS COULD RESULT IN ESCAPING GAS THAT COULD IGNITE AND CAUSE PROPERTY DAMAGE, SERIOUS INJURY OR DEATH.**



## IMPORTANT

**THE HYMAX GRIP** is a stab-on type restraint coupling, that is approved for use with metal and plastic pipes when installing a new element in the existing line.

**THE HYMAX GRIP SERIES ARE STAB-ON TYPE COUPLINGS.** Do not disassemble the product. Do not loosen the bolts

**LUBRICATION OF PRODUCT AND PIPES** except steel, PVC, and PE pipes, all rough-surfaced pipes must be lubricated with a water-based gasket lubricant in order to achieve a proper seal. Do not lubricate PVC, Steel or PE pipe surface.

**DO NOT LUBRICATE BOLTS AND NUTS.** Bolts are pre-lubricated with a MAG (Molecular anti-galling) coating. Greasing bolts or nuts voids manufacturer's warranty.

**TIGHTEN BOLTS TO THE TORQUE** value provided on the label in one continuous step. Krausz products do not require a gradual increase of torque over a specified period, nor do they require re-torque. The minimal torque requirements must be achieved prior to any recharging of the line.

**USE A TORQUE WRENCH TO TIGHTEN THE BOLTS.** A torque wrench will assure a proper torque has been applied to the coupling. Do not use other tools to tighten the coupling's bolts!

**PIPE STIFFENERS OR INSERTS ARE REQUIRED** when used on HDPE pipes

**DO NOT USE HYMAX GRIP ON AC OR FRP PIPES!**

# PREPARE PRODUCT AND PIPE FOR INSTALLATION:

1

## CLEAN AND DESCALE THE PIPE

**Make sure that:**

- The pipe is clear from debris
- The pipe is not out of round and is free of scratches, dents, flats and defects
- The end rings are centered on the coupling - if they are not, please contact your local distributor for return and replacement

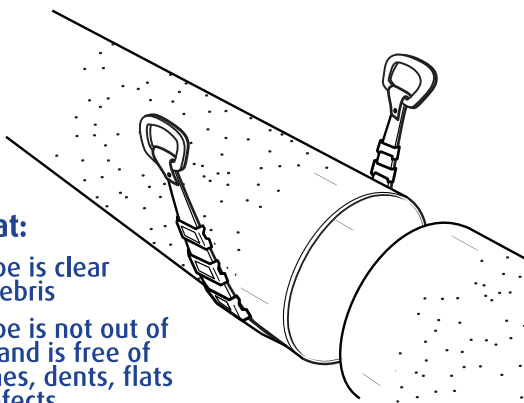

2

## MEASURE THE PIPE TWICE

**Make sure that:**

the coupling size range (as indicated on the product's label) will fit the pipes properly

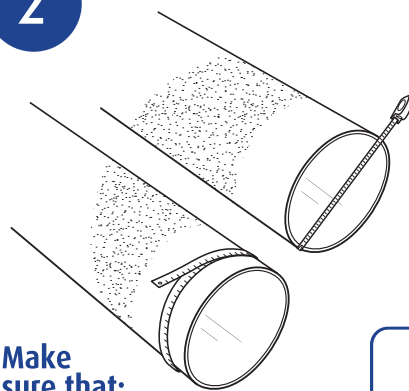

RANGE

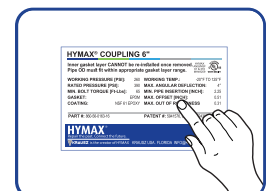

# INSTALLATION OF THE COUPLING:

3

## MARK EACH PIPE END FOR MINIMUM PIPE INSERTION DISTANCE

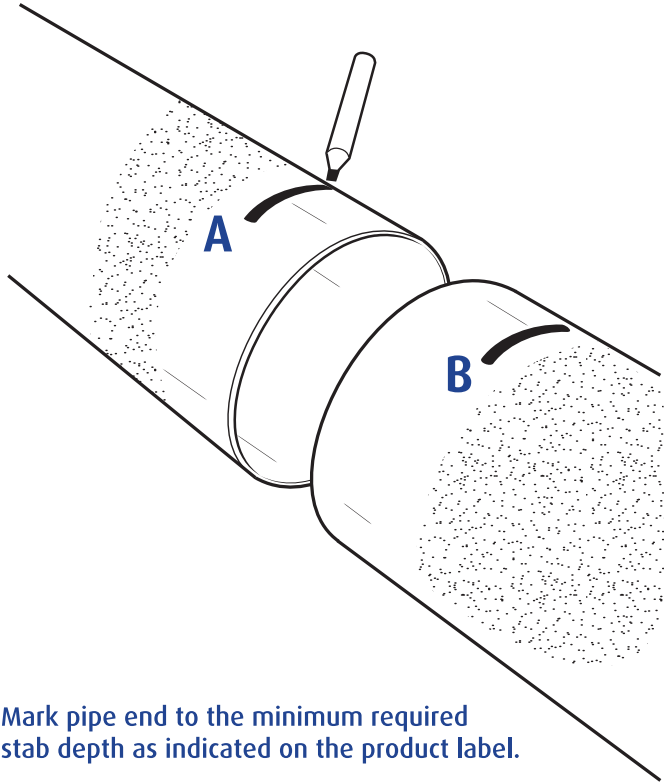

Mark pipe end to the minimum required stab depth as indicated on the product label.

4

## THE HYMAX GRIP FITS A WIDE RANGE OF PIPE SIZES. THE GRIP RANGE IS SHOWN ON THE PRODUCT'S LABEL

For sizes 1.5"-3" only:

The inner gasket can be removed to accommodate larger OD pipes.

If a larger OD is required, fold the inner layer, separate the two gaskets by inserting a screwdriver between the two layers, and pull the layer out of the product.

A

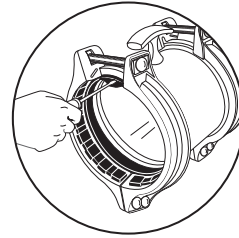

B

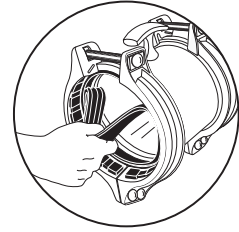

C

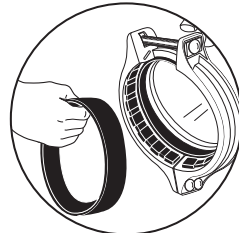

**NOTE:** Do not remove the inner gasket unless the OD falls within the upper range of the product. The proper range sizes are shown on the product label.

5

## POSITION THE COUPLING FOR INSTALLATION

- Slide the product on both sides of the replacement pipe with top-facing bolts and lower the pipe and couplings into the ditch. Lower the replacement pipe, and the HYMAX GRIP positioned on it, into the ditch.

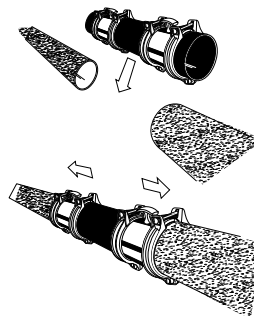

- Slide the Grips outward so that they cover the marks made in step 3.

- Make sure that the pipes are not touching inside the body of the product. there must be space between the pipes for Continuous Dynamic Deflection to take place.

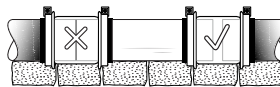

- Make sure that the pipes are properly supported. The HYMAX GRIP is not designed to carry the weight of the pipes.

- For Flange Adaptor: assemble the flange joint using flange bolts. Make sure you use a flat gasket between the flanges (not provided).

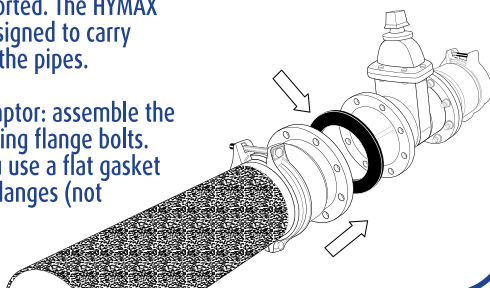

6

## TIGHTEN

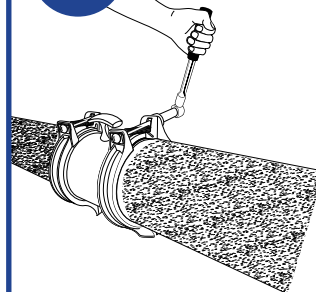

Tighten the Grip's bolts to the right torque shown on the product label. When you finish, re-check the torque again.

## TORQUE

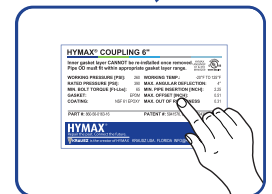

7

## RECHARGE

Recharge the line and check for leaks. If any leakage is evident, reduce the pressure in the line and increase bolt torque by up to 50%. For 1.5"-3" increase bolt torque by up to 30%.

Verify again no leaks are evident along the seal.

# HYMAX<sup>®</sup>

Repair the past. Connect the future.

---

 **KRAUSZ** is the creator of HYMAX