

AWWA C900 PVC PIPE							
NOMINAL PIPE SIZE	BASE CATALOG NUMBER	THREAD TYPE	SIZE OF TAPPING				FASTENER MATERIAL
			.75"	1"	1.5"	2"	
10"	OD2B1110	CC or IP	075	100	-	-	S6
12"	OD2B1320	CC or IP	075	100	-	-	S6

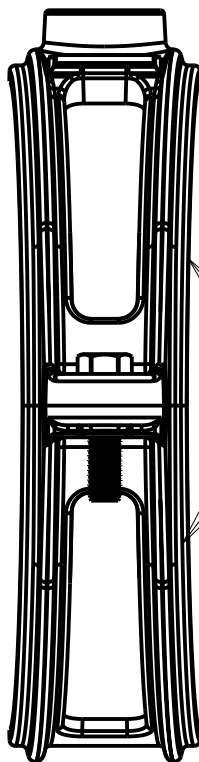
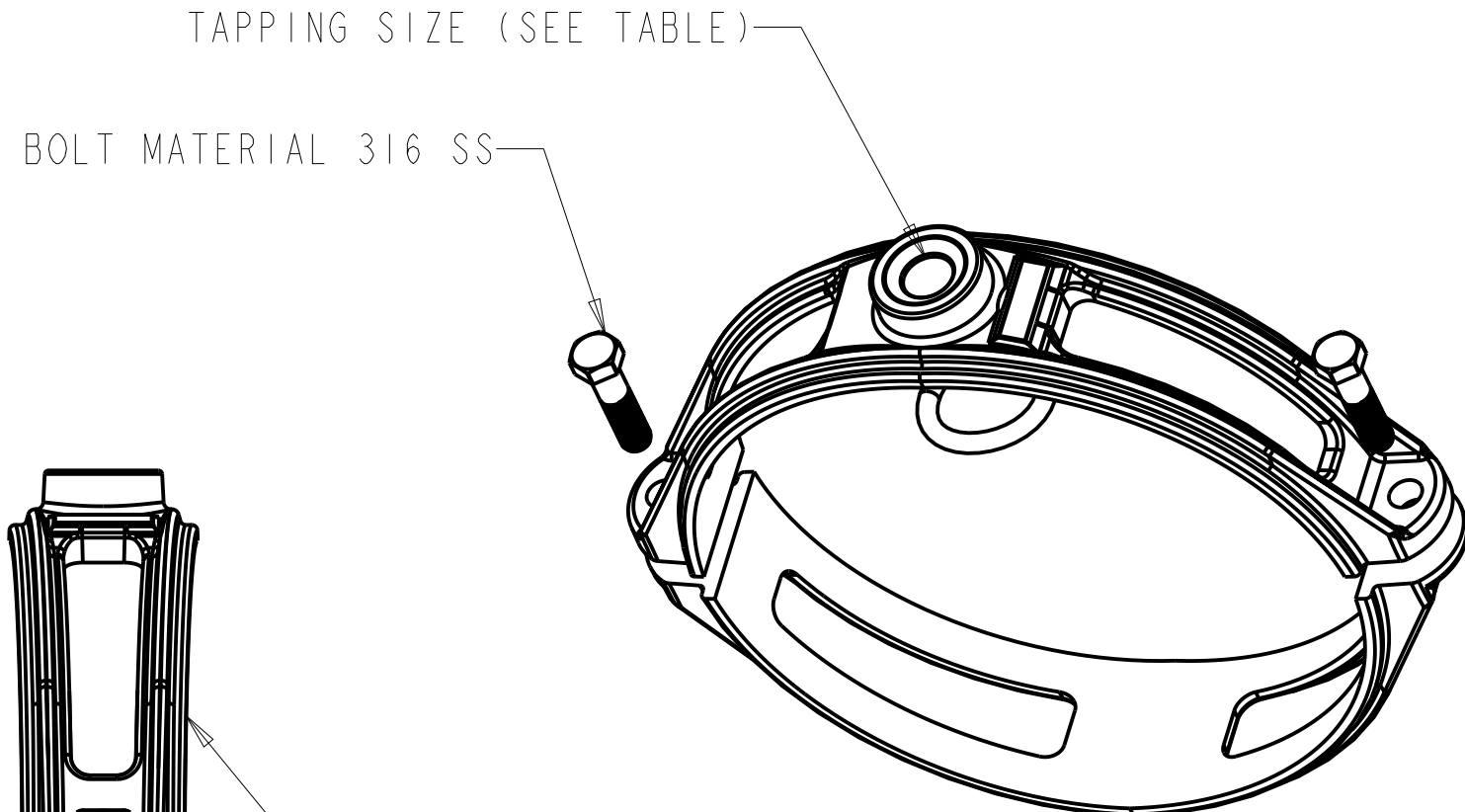
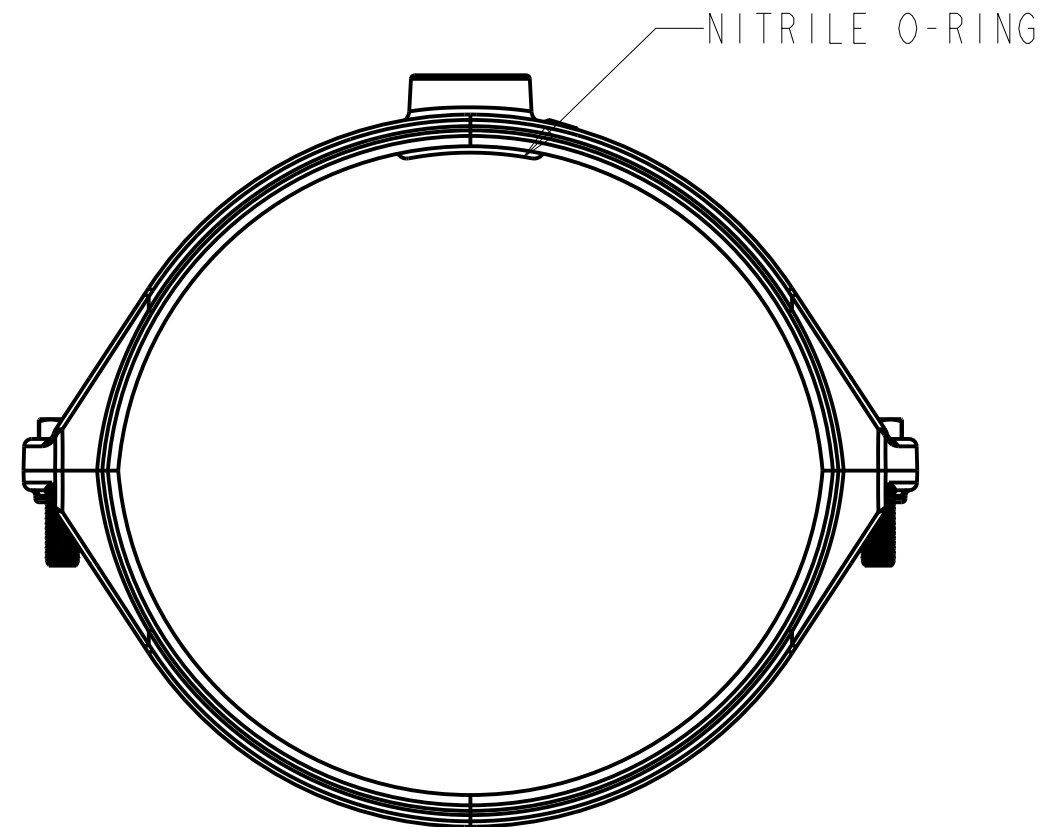
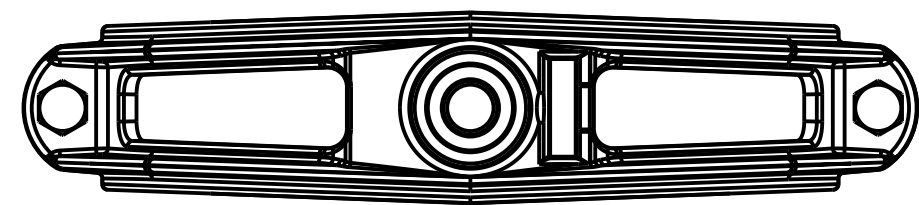

OD2B-S6

DR. BY	TBE	10/17/17	UNLESS OTHERWISE NOTED		THIRD ANGLE PROJECTION		C.B. NO.	
CHKR			BREAK CAST CORNER(S)---					
ENGR			BREAK MACH CORNER(S)---		PURCH.	FINISH	PATT. NO.	
MGR			TOLERANCES		REF. NO.	SCALE		
MFG			UNLESS OTHERWISE NOTED		NONE			
TOOL			LINEAR	ANGULAR	STK. NO.			
FDRY			±	±				
MAT'L: SEE PRINT								
Mueller Co.			DESCR. OD SERIES SERVICE SADDLES FOR C900 PVC PIPE SIZES 10" THROUGH 12" WITH 316 SS FASTENERS				NUMBER	OD2B-S6