

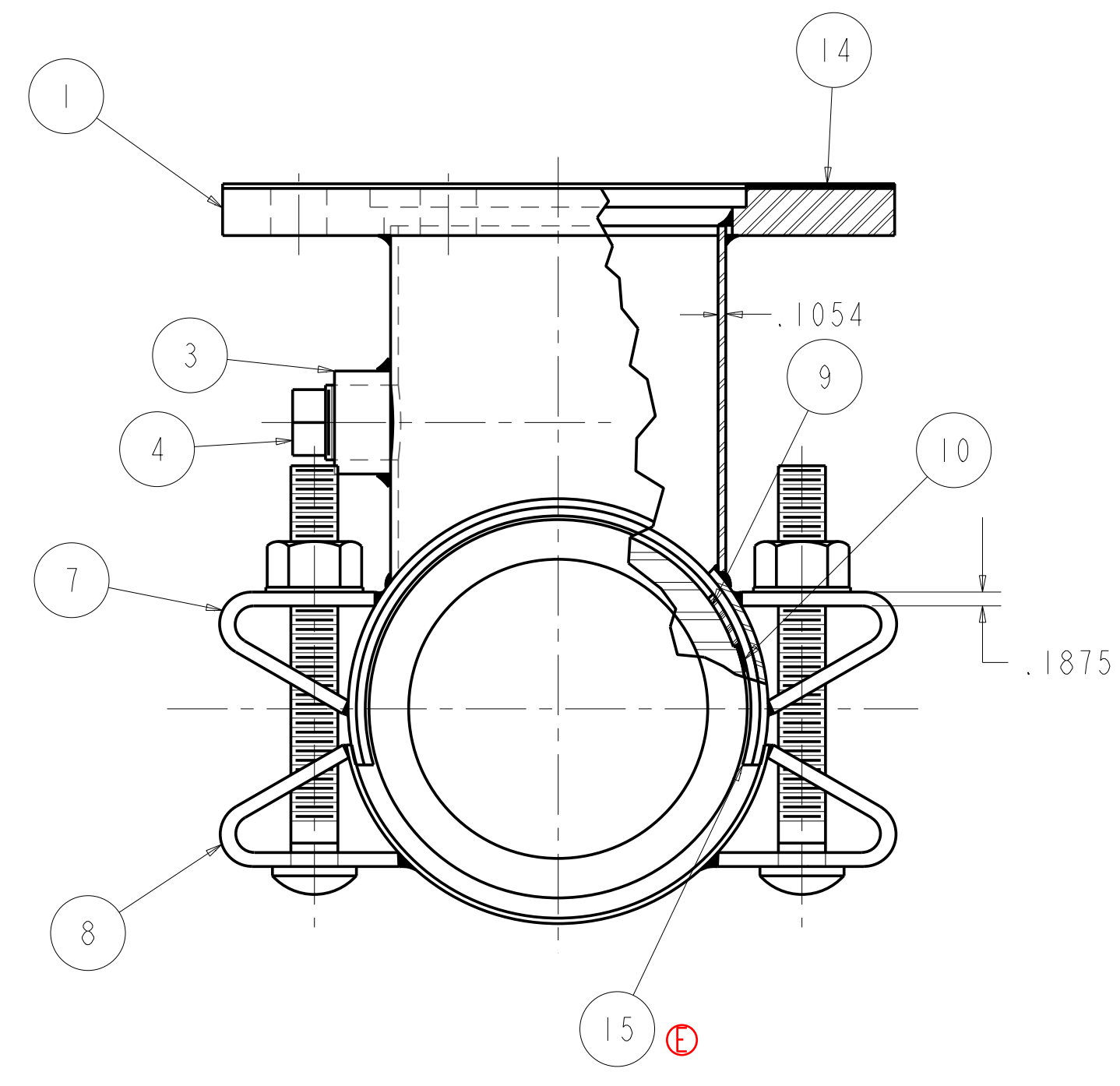

6628 MUELLER FABRICATED STAINLESS STEEL TAPPING SLEEVES 4X4 THRU 24X12 SIZES H304

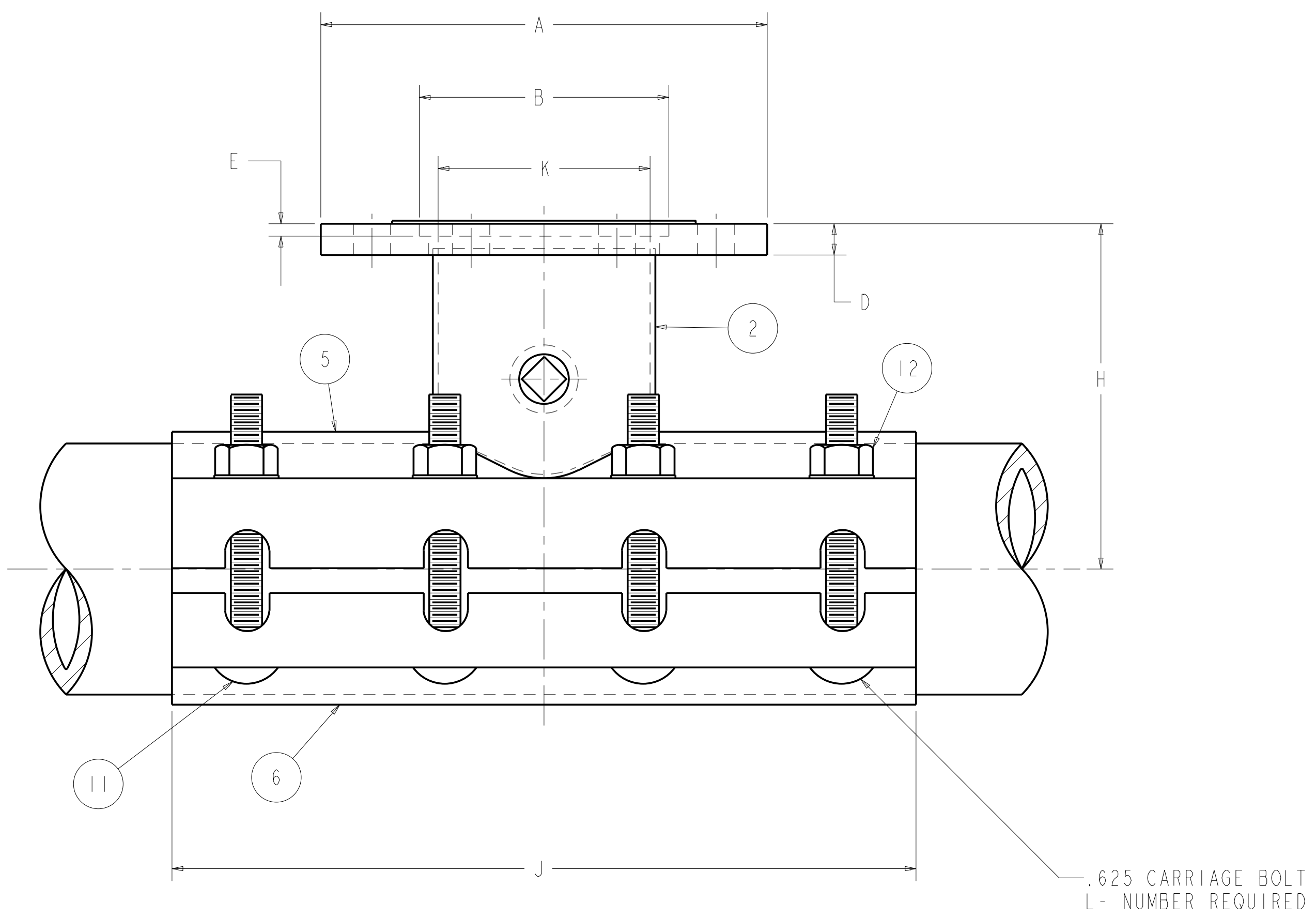
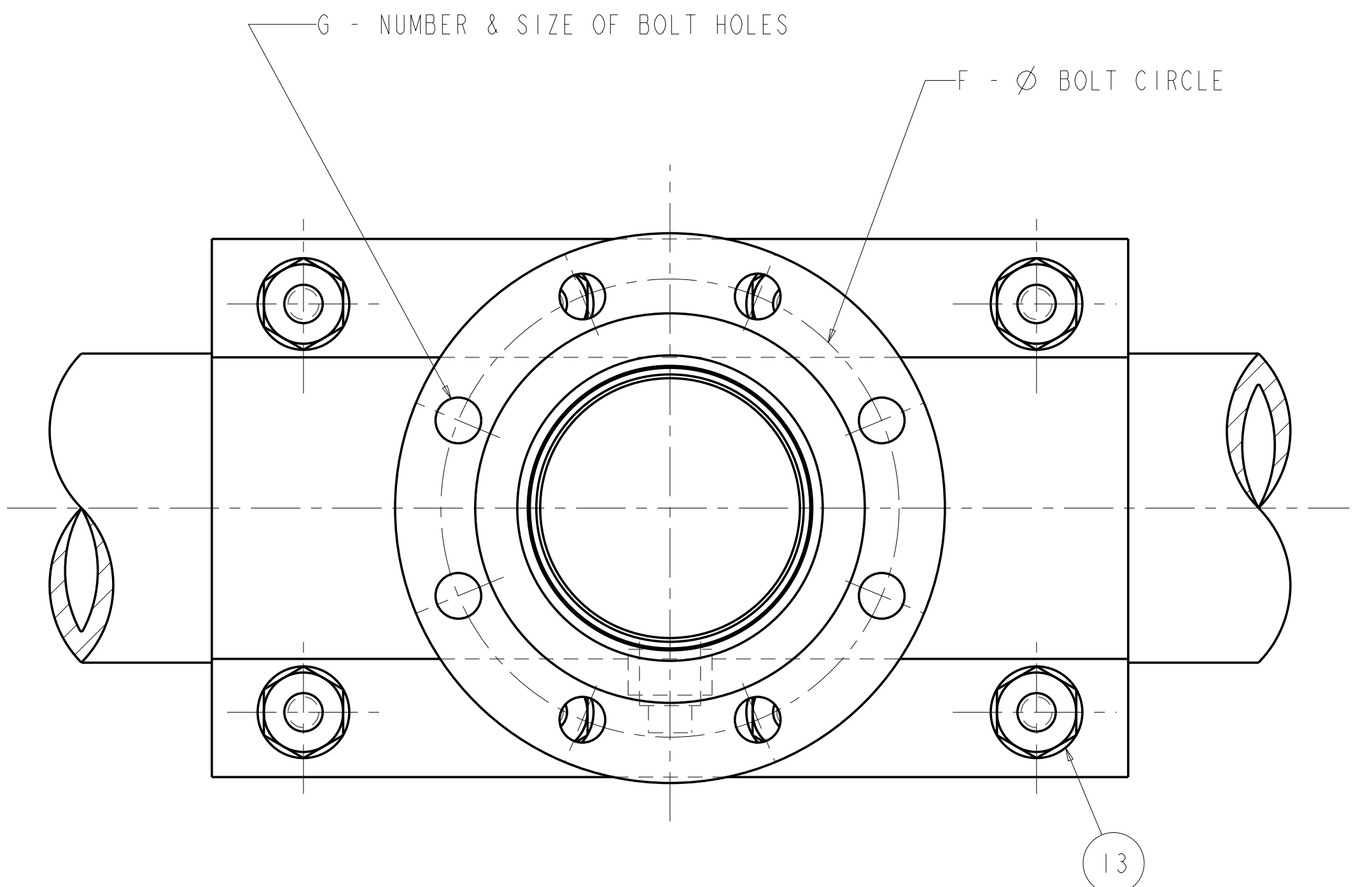

PARTS LIST					
ITEM	DESCRIPTION	REQ'D	MATERIAL	ASTM	
1-A	FLANGE 1	1	CARBON STEEL	Ⓐ A519	ⒶGR. 1018-1026
1-B	FLANGE 2	1	STAINLESS STEEL	Ⓐ A276	304L
1-C	FLANGE 3	1	DUCTILE IRON	Ⓒ A536	70-50-05
2	NECK	1	STAINLESS STEEL	Ⓒ A240	304L
3	COUPLING	1	STAINLESS STEEL	Ⓒ A240	304L
4	PLUG	1	BRASS	Ⓒ B129	C26000
5	OUTLET BAND	1	STAINLESS STEEL	Ⓒ A240	304L
6	CAP BAND	1	STAINLESS STEEL	Ⓒ A240	304L
7	OUTLET BOLT BARS	2	STAINLESS STEEL	Ⓒ A240	304L
8	CAP BOLT BARS	2	STAINLESS STEEL	Ⓒ A240	304L
9	DOUGH NUT GASKET	1	RUBBER	D2000	
10	PIPE GASKET	1	RUBBER	D2000	
11	CARRIAGE BOLTS	L	STAINLESS STEEL	A193	GRADE B-8
12	NUTS	L	STAINLESS STEEL	A194	GRADE 8
13	WASHERS	L	STAINLESS STEEL	Ⓒ A193	300 SERIES
14	FLANGE GASKET	1	RUBBER	D2000	
15	END RETAINERS ***	2	STAINLESS STEEL	A240	304L

\*\*\* FOR TAPPING SLEEVE SIZES 10" AND GREATER

OUTLET FLANGE DIMENSIONS							
SIZE	A	B	* D1	** D2	E	F	G
4	9.00	5.0315	.719	.969	.25	7.50	8- .75
6	11.00	7.0315	.781	1.031	.31	9.50	8- .88
8	13.50	9.0315	.781	1.156	.31	11.75	8- .88
10	16.00	11.0315	.781	1.219	.31	14.25	12-1.00
12	19.00	13.0315	.906	1.281	.31	17.00	12-1.00

\* D1= CARBON STEEL AND STAINLESS STEEL  
\*\* D2= DUCTILE IRON

SLEEVE DIMENSIONS						
SIZE	SIZE		H	J	K <sup>Ⓓ</sup>	L
	MAIN	OUTLET				
4	4	4	7.00	15	4.50	8
6	4	4	7.50	15	4.50	8
6	6	6	8.00	15	6.50	8
8	4	4	8.50	15	4.50	8
8	6	6	9.00	15	6.50	8
8	8	8	9.50	18	8.50	12
10	4	4	10.00	15	4.50	8
10	6	6	10.50	15	6.50	8
10	8	8	11.00	18	8.50	12
10	10	10	11.50	24	10.50	16
12	4	4	12.00	15	4.50	8
12	6	6	12.00	15	6.50	8
12	8	8	12.00	18	8.50	12
12	10	10	12.00	24	10.50	16
12	12	12	12.00	30	12.50	16
14	4	4	13.63	15	4.50	8
14	6	6	13.63	15	6.50	8
14	8	8	13.63	18	8.50	12
14	10	10	13.63	24	10.50	16
14	12	12	13.63	30	12.50	16
16	4	4	14.69	15	4.50	8
16	6	6	14.69	15	6.50	8
16	8	8	14.69	18	8.50	12
16	10	10	14.69	24	10.50	16
16	12	12	14.69	30	12.50	16
18	4	4	16.00	15	4.50	8
18	6	6	16.00	15	6.50	8
18	8	8	16.00	18	8.50	12
18	10	10	16.00	24	10.50	16
18	12	12	16.00	30	12.50	16
20	4	4	16.88	15	4.50	8
20	6	6	16.88	15	6.50	8
20	8	8	16.88	18	8.50	12
20	10	10	16.88	24	10.50	16
20	12	12	16.88	30	12.50	16
24	4	4	19.00	24	4.50	16
24	6	6	19.00	24	6.50	16
24	8	8	19.00	24	8.50	16
24	10	10	19.00	24	10.50	16
24	12	12	19.00	30	12.50	20

**MUELLER CONFIDENTIAL**  
Title to and ownership of this engineering data remains in Mueller Co. No use is to be made of this data except as specifically authorized by Mueller Co. Assent on the part of recipients to these conditions is presumed.

Ⓐ 20 WAS 16 ECN 1380 JWB 5/30/97	Ⓓ ECN 1498 A519 WAS A216 GR. 1018-1026 WAS GR. WBC ADDED ASTM A276 JLC 2/9/98	Ⓒ ECN 1699 ADDED ASTM NOS. JLC 7/21/98	Ⓔ ECO 1033701 4.50, 6.50, 8.50, 10.50, & 12.50 WAS 4.38, 6.38, 8.38, 10.38, & 12.38 JLC 10/25/00	Ⓔ ECO 1272622 ADDED END RETAINERS CAP 11/11/02
--	--	---	--	---

**Prior Approval Sign-off**  
Eng. Mgr. TRJ  
11/11/02

SR BY: JWB 4/12/97	UNLESS OTHERWISE NOTED	THIRD ANGLE PROJECTION	C. D. NO.
CHKD:	BREAK CAST CORNERS!		PART. NO.
ENGR:	BREAK MACH CORNERS!	PURCH. FINISH	
MGR:	TOLERANCES	REF. NO. SCALE NONE	
MFG:	UNLESS OTHERWISE NOTED	STR. NO.	
TOOL:	LINEAR	ANGULAR	
FBY:	±	±	

MAT'L NOTED  
**Mueller Co.** FABRICATED STAINLESS STEEL TAPPING SLEEVES 4X4 THRU 24X12 SIZES H304  
NUMBER 6628