

OUTLET FLANGE DIMENSIONS						
OUTLET SIZE	A	B	D	E	F	G
3	7.50	4.0315	.719	.22	6.00	4- .75
4	9.00	5.0315	.719	.25	7.50	8- .75
6	11.00	7.0315	.781	.31	9.50	8- .88
8	13.50	9.0315	.781	.31	11.75	8- .88
10	16.00	11.0315	.781	.31	14.25	12-1.00
12	19.00	13.0315	.906	.31	17.00	12-1.00

PARTS LIST						
ITEM	DESCRIPTION	REQ'D	MATERIAL	ASTM	GRADE	THICKNESS
1	FLANGE	1	CARBON STEEL	A105		
				A519	1018-1026	
2	NECK	1	CARBON STEEL	A36		3/16"
3	HALF COUPLING	1	STAINLESS STEEL	A240	304L	
4A	PLUG	1	BRASS	B129	C26000	
4B	PLUG	1	STAINLESS STEEL**	A240	304L	
5	OUTLET BAND	1	CARBON STEEL	A36		3/8"*
6	CAP BAND	1	CARBON STEEL	A36		3/8"*
7	OUTLET GASKET	1	RUBBER NITRILE	D2000	DUROMETER 60	
8A	CARRIAGE BOLTS	L	ZINC PLATED CARBON STEEL	A307	A OR B	
8B	CARRIAGE BOLTS	L	STAINLESS STEEL**	F593	GR. 1 COND. A	
				A193	GR. B8 CL. 1	
9A	NUTS	L	ZINC PLATED CARBON STEEL	A563	A	
9B	NUTS	L	TEFLON COATED STAINLESS STEEL**	F594	GR. 1 COND. A	
				A194	GR. 8F CL. 2B	
10A	WASHERS	L	ZINC PLATED CARBON STEEL	A307	B	
10B	WASHERS	L	STAINLESS STEEL**	A240	304L	
11	COATING	OUTLET AND CAP	RILSAN POWDER COAT	D1235		.015"

G - NUMBER & SIZE OF BOLT HOLES

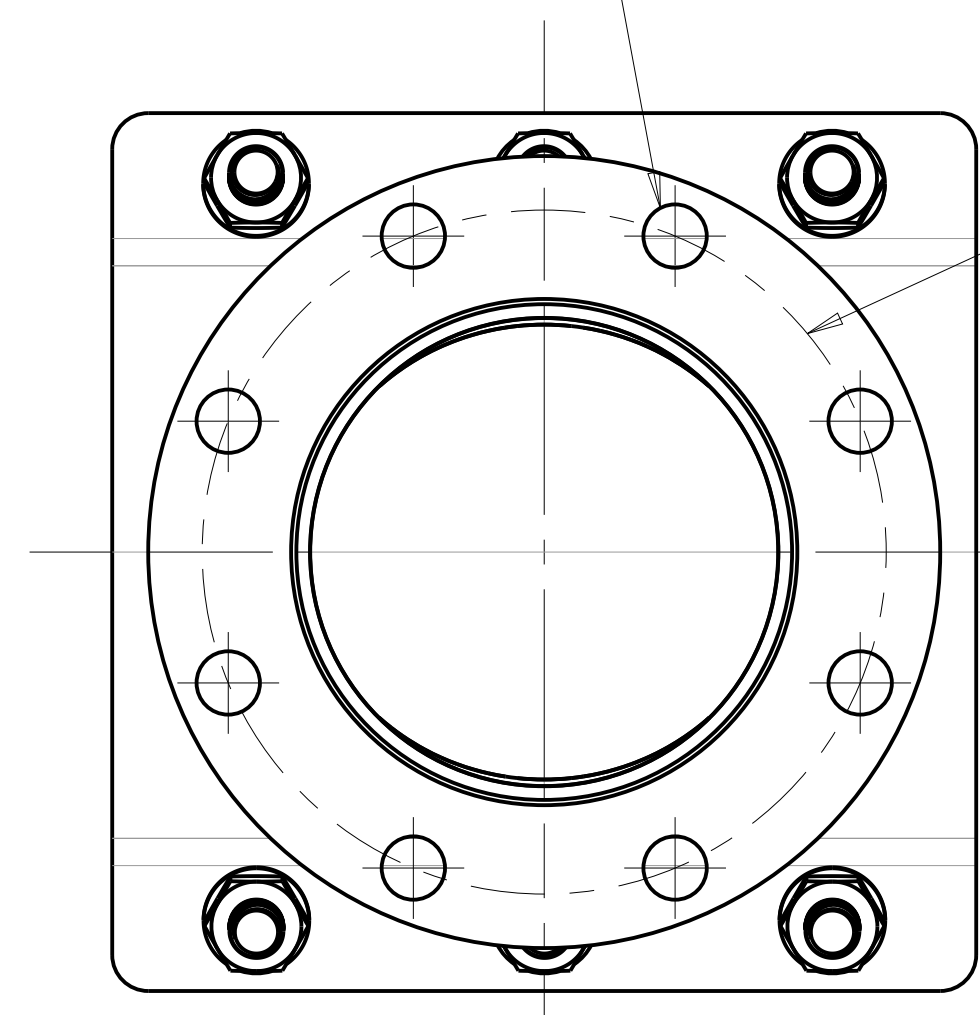

F - Ø BOLT CIRCLE

N-TOTAL NUMBER OF GUSSETS

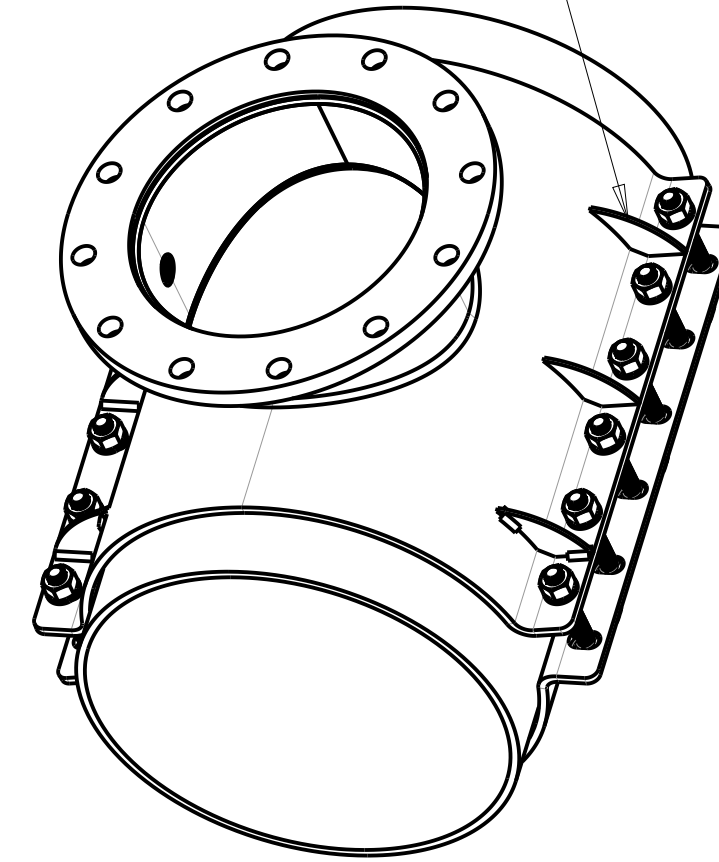

*CAP AND OUTLET BAND THICKNESS IS 5/16" IN 4" MAIN SIZES

**THE H306 TAPPING SLEEVE IS AVAILABLE IN STANDARD AND STAINLESS STEEL HARDWARE CONFIGURATIONS

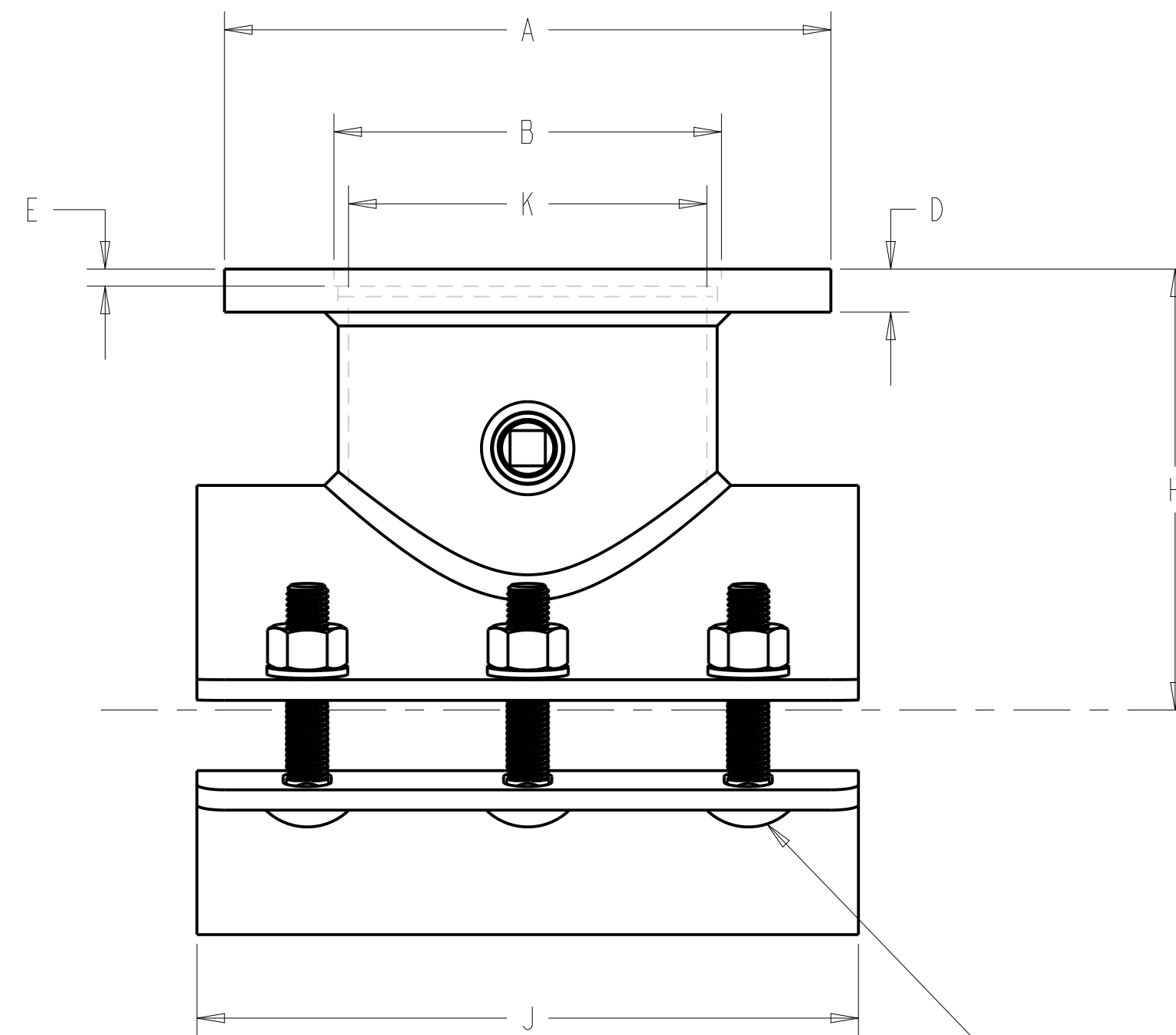

M-SIZE OF CARRIAGE BOLT
L-NUMBER REQUIRED

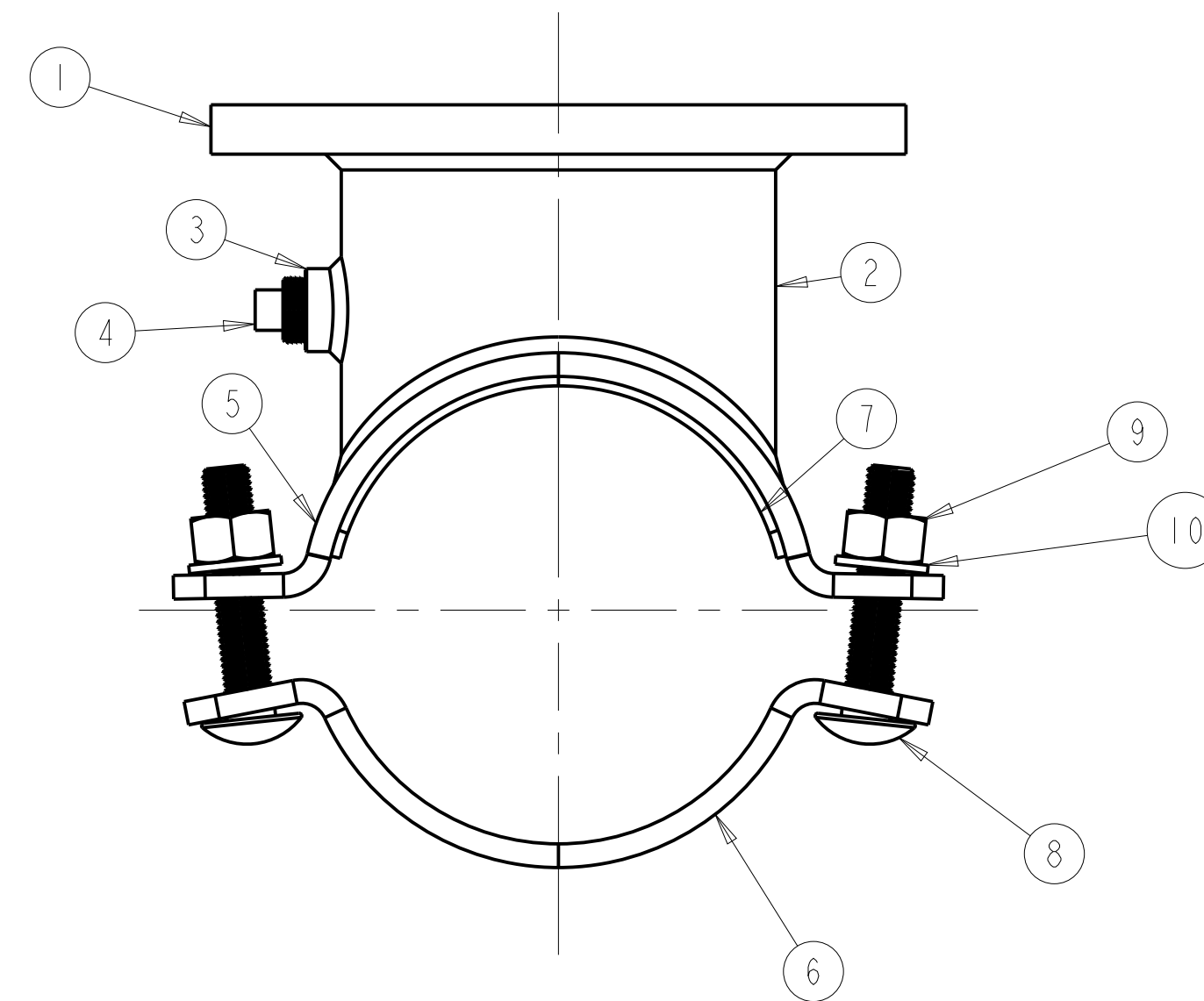

TAPPING SLEEVE PIPE INFORMATION		
MAIN	OUTLET SIZES	AVAILABLE OD RANGE
4	3 & 4	4.50 ONLY
4	3 & 4	4.80 ONLY
6	3, 4, & 6	6.57 - 6.73
6	3, 4, & 6	6.86 - 7.16
6	3, 4, & 6	7.10 - 7.40
6	3, 4, & 6	7.43 - 7.73
8	3, 4, 6, & 8	8.46 - 8.75
8	3, 4, 6, & 8	8.82 - 9.12
8	3, 4, 6, & 8	9.07 - 9.37
8	3, 4, 6, & 8	9.39 - 9.69
8	3, 4, 6, & 8	9.95 - 10.25
10	3, 4, 6, 8, & 10	10.64 - 10.86
10	3, 4, 6, 8, & 10	10.95 - 11.25
10	3, 4, 6, 8, & 10	11.17 - 11.47
10	3, 4, 6, 8, & 10	11.50 - 11.80
10	3, 4, 6, 8, & 10	11.64 - 11.94
10	3, 4, 6, 8, & 10	11.94 - 12.24
12	3, 4, 6, 8, 10, & 12	12.58 - 12.88
12	3, 4, 6, 8, 10, & 12	13.05 - 13.35
12	3, 4, 6, 8, 10, & 12	13.30 - 13.60
12	3, 4, 6, 8, 10, & 12	13.79 - 14.09
12	3, 4, 6, 8, 10, & 12	14.28 - 14.58
14	3, 4, 6, 8, 10, & 12	14.78 - 15.08
14	3, 4, 6, 8, 10, & 12	15.15 - 15.45
14	3, 4, 6, 8, 10, & 12	15.42 - 15.72
14	3, 4, 6, 8, 10, & 12	15.62 - 15.92
14	3, 4, 6, 8, 10, & 12	15.92 - 16.22
14	3, 4, 6, 8, 10, & 12	16.15 - 16.45
16	3, 4, 6, 8, 10, & 12	16.43 - 16.73
16	3, 4, 6, 8, 10, & 12	16.68 - 16.98
16	3, 4, 6, 8, 10, & 12	16.96 - 17.26
16	3, 4, 6, 8, 10, & 12	17.27 - 17.57
16	3, 4, 6, 8, 10, & 12	17.57 - 17.87
16	3, 4, 6, 8, 10, & 12	17.83 - 18.13
16	3, 4, 6, 8, 10, & 12	18.13 - 18.43

SLEEVE DIMENSIONS							
MAIN	OUTLET	H	J	K	L	M	N
4	3	7.00	12	3.5	6	.75	0
4	4	7.00	12	4.5	6	.75	0
6	3	7.50	12	3.5	6	.75	0
6	4	7.50	12	4.5	6	.75	0
6	6	8.00	12	6.5	6	.75	0
8	3	8.50	12	3.5	6	.75	0
8	4	8.50	12	4.5	6	.75	0
8	6	9.00	12	6.5	6	.75	0
8	8	9.50	16	8.5	8	.75	0
10	3	10.00	12	3.5	6	.75	0
10	4	10.00	12	4.5	6	.75	0
10	6	10.50	12	6.5	6	.75	0
10	8	11.00	16	8.5	8	.75	0
10	10	11.50	20	10.5	10	.75	0
12	3	12.00	12	3.5	6	.75	0
12	4	12.00	12	4.5	6	.75	0
12	6	12.00	12	6.5	6	.75	0
12	8	12.00	16	8.5	8	.75	0
12	10	12.00	20	10.5	10	.75	0
12	12	12.00	24	12.5	12	.75	0
14	3	13.63	12	3.5	6	.75	8
14	4	13.63	12	4.5	6	.75	8
14	6	13.63	12	6.5	6	.75	8
14	8	13.63	16	8.5	8	.75	8
14	10	13.63	20	10.5	10	.75	8
14	12	13.63	24	12.5	12	.75	12
16	3	14.59	12	3.5	6	.75	8
16	4	14.59	12	4.5	6	.75	8
16	6	14.59	12	6.5	6	.75	8
16	8	14.59	16	8.5	8	.75	8
16	10	14.59	20	10.5	10	.75	8
16	12	14.59	24	12.5	12	.75	12

H306-CS

ECO 1700059
 ECO 1700090
 9.45 - 10.25 SIZE RANGE
 MOVED FROM MAIN
 SIZE 10" to 8"
 TBE 4/23/18

DR BY: TBE 4/28/17	UNLESS OTHERWISE NOTED	THIRD ANGLE PROJECTION	C.B. NO.
ENGR:	BREAK CAST CORNERS!		PART. NO.
MGR:	BREAK MACH CORNERS!	PURCH. NO.	FINISH ASSY
WFO:	TOLERANCES UNLESS OTHERWISE NOTED	REF. NO.	SCALE NONE
TOOL:	LINEAR	ANGULAR	SCALE NONE
FBY:		STK. NO.	
MAT'L: NOTED			
Mueller Co.	DESCR: FABRICATED STEEL TAPPING SLEEVE 4X3 THROUGH 16X12 SIZES H306	NUMBER	H306-CS