

PIPE SIZE	PIPE RANGE	TYPE	TAP THREAD*	AVAILABLE TAP SIZES						
				1/2"	5/8"	3/4"	1"	1-1/4"	1-1/2"	2"
4"	4.74-5.32	BR2B0474	CC OR IP	050	062	075	100	-	-	-
4"	4.74-5.10	BR2B0474	CC OR IP	-	-	-	-	125	150	200
4"	5.10-5.40	BR2B0510	CC OR IP	-	-	-	-	125	150	200
6"	6.84-7.45	BR2B0684	CC OR IP	050	062	075	100	125	150	200
8"	8.99-9.67	BR2B0899	CC OR IP	050	062	075	100	125	150	200
10"	11.04-12.12	BR2B1104	CC OR IP	050	062	075	100	125	150	200
12"	13.14-14.58	BR2B1314	CC OR IP	050	062	075	100	125	150	200
14"	15.22-16.88	BR2B1522	CC OR IP	-	-	075	100	-	150	200
16"	17.32-19.19	BR2B1732	CC OR IP	-	-	075	100	-	150	200

*IP STANDS FOR AWWA I.P. THREAD (F.I.P.T.)
 CC STANDS FOR AWWA TAPER THREAD (C.C.)

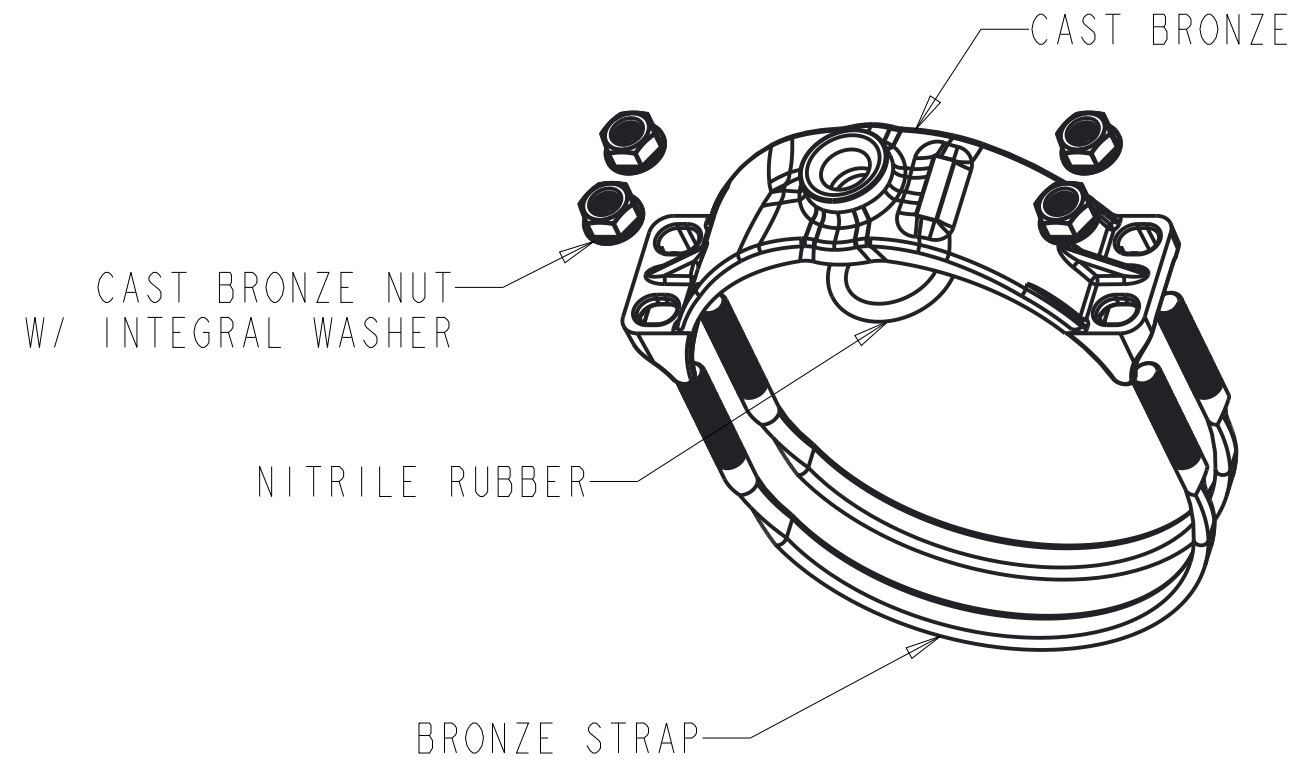
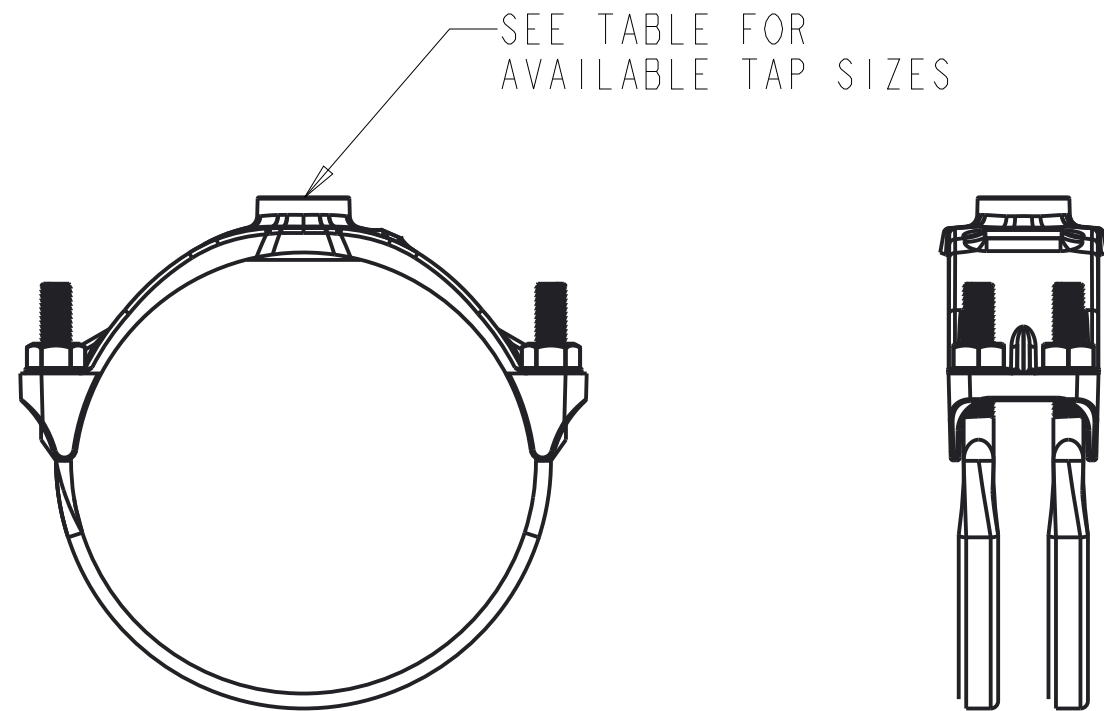

BR2B

DR. BY	TBE	07/19/17	UNLESS OTHERWISE NOTED	THIRD ANGLE PROJECTION	C.B. NO.
CHKR			BREAK CAST CORNER(S)---		
ENGR			BREAK MACH CORNER(S)---	PURCH.	PATT. NO.
MGR			TOLERANCES	FINISH	
MFG			UNLESS OTHERWISE NOTED	REF. NO.	SCALE
TOOL			LINEAR	ANGULAR	
FDRY			±	±	STK. NO.
MAT'L: SEE DRAWING CALLOUTS					
			DESCR.	NUMBER	
			4" - 16" BR2B STYLE SERVICE SADDLE WITH ALL AVAILABLE TAP OPTIONS	BR2B	