

REVISIONS					
REV.	DESCRIPTION	ECO	DRAWN	APPROVED	DATE
A	Release for Production		Shlomo B.	Tzah. Gr.	10/01/2023

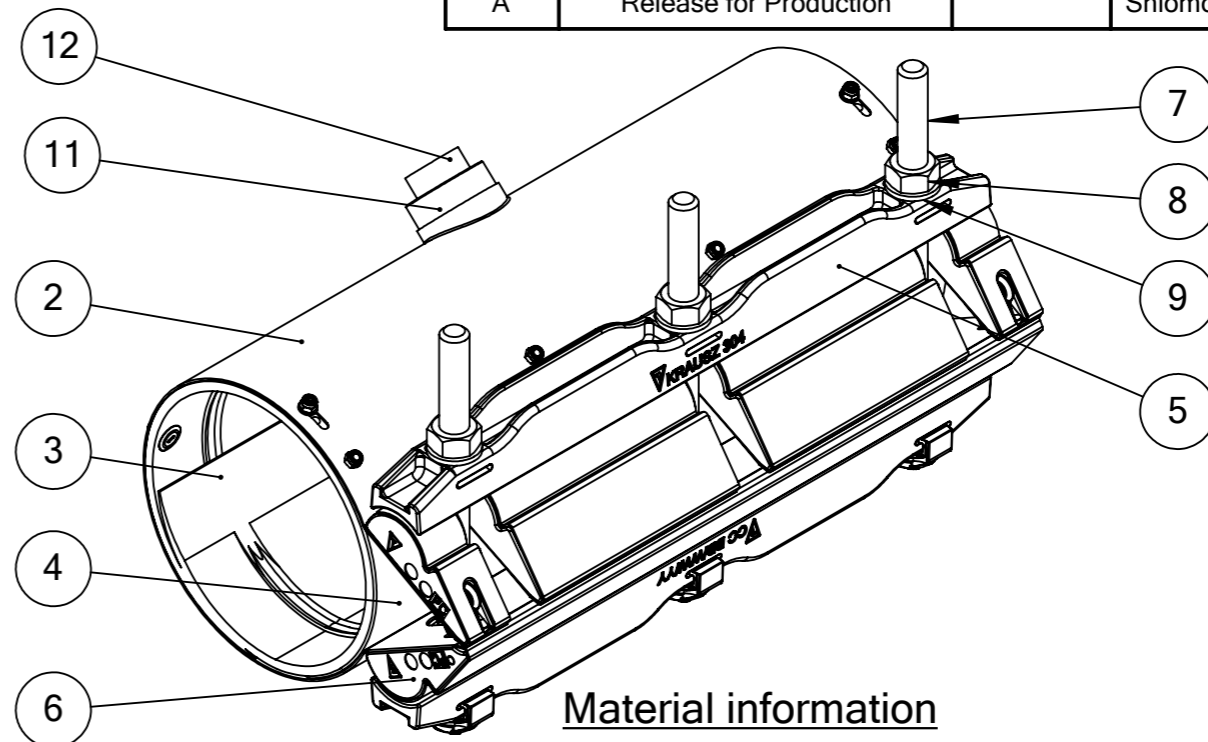

**Material information**

1. Hymax Clamp Outlet meets AWWA C230 standard.
2. Body - AISI 304 Stainless Steel  
ASTM A240 / ASTM A480.
3. Pressure Assisted Gasket - EPDM compounded for water and sewerage in accordance with ASTM D2000  
Working Temperature:  
For continuous operations: -20°F up to +180°F  
For short time operations: up to +215°F
4. Gasket Bridge - AISI 304 Stainless Steel ASTM A240.
5. Compression Beam - Casting AISI 304 of ASTM-A351-CF8.
6. Lugs - Polycarbonate.
7. Bolt- AISI 304 Stainless Steel ASTM F593.  
Rolled thread and anti-galling coating.
8. Nuts - AISI 304 Stainless Steel ASTM F594.  
Rolled thread and anti-galling coating.
9. Washers - AISI 304 Stainless Steel ASTM A240.
10. Adjusting Pin - Casting AISI-304 of ASTM-A351-CF8.
11. Thread Tap 3/4" CC - AISI 304 Stainless Steel.
12. Plug 3/4" CC -Casting AISI 304.

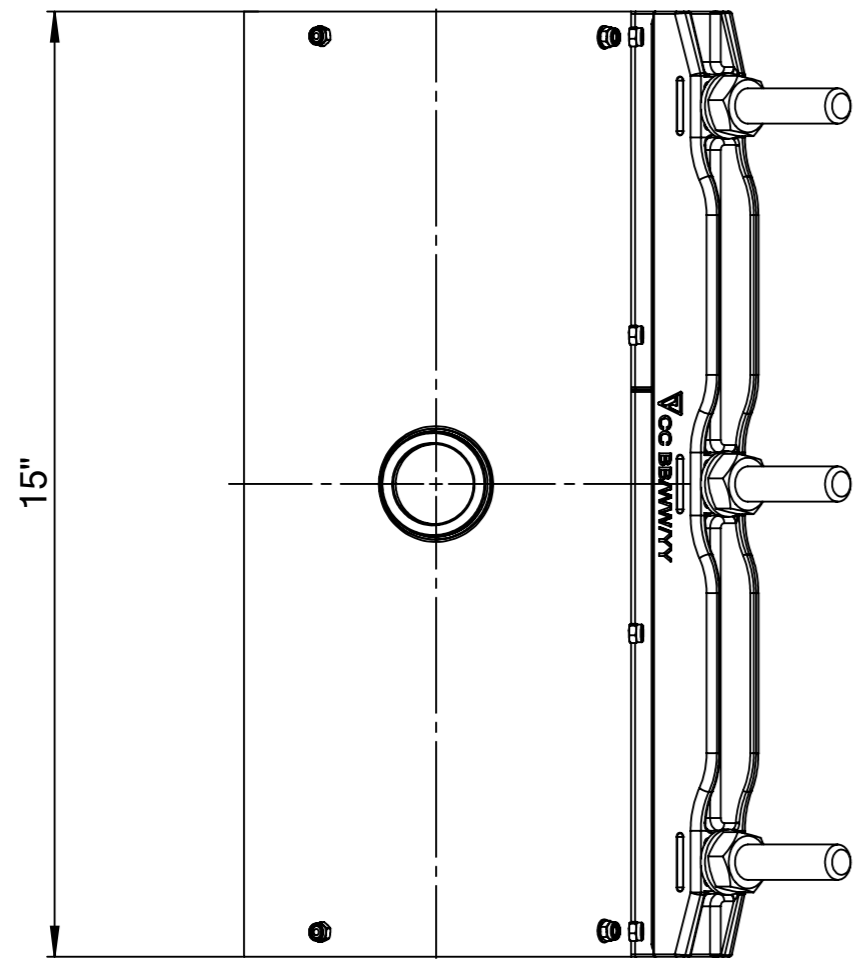

Weight:		Part Name: Hymax Clamp Outlet Thread Tap 3/4"CC Length 15" with Plug		Scale
Design	11/01/2017	Name	Catalog No. SD238-56-06	Size A3
Check	10/01/2023	Shlomo B.	Drawing No. SD238-56-06	Sheet 1 of 2
Appr.	10/01/2023	Tzah. Gr.		

**RELEASED**



Confidential Information. All rights reserved to Krausz Industries Ltd. This document may not be copied, reproduced, displayed, modified or used in any way, whether in whole or in part, without the express prior written consent of Krausz Industries Ltd.

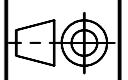

REVISIONS					
REV.	DESCRIPTION	ECO	DRAWN	APPROVED	DATE
A	Release for Production		Evgeny K.	Tzah. Gr.	10/01/2023

Krausz Part Number	ND	Range (inch)	H (inch)	CC Outlet Size	Bolts Qty.-Size d(mm)	Bolts Length L (inch)	Torque (Ft-Lbs)
238-56-0113-075C-10-P	4"	4.45-4.84	8.0	3/4"	3-M14	8.27	75
238-56-0120-075C-10-P	4"	4.72-5.12	8.4	3/4"	3-M14	8.27	75
238-56-0125-075C-10-P	4"	4.92-5.35	8.7	3/4"	3-M14	8.27	80
238-56-0132-075C-10-P	5"	5.20-5.60	9.0	3/4"	3-M14	8.27	80
238-56-0174-075C-10-P	6"	6.84-7.64	10.6	3/4"	3-M14	8.27	80
238-56-0228-075C-10-P	8"	9.00-9.80	12.8	3/4"	3-M14	8.27	95
238-56-0272-075C-10-P	10"	10.73-11.53	14.6	3/4"	3-M14	8.27	135
238-56-0323-075C-10-P	12"	12.75-13.55	16.7	3/4"	3-M16	9.45	150

Product performance	
Working Pressure	150 PSI
Rated Pressure	225 PSI

Weight:		Part Name: Hymax Clamp Outlet Thread Tap 3/4"CC Length 15" with Plug		Scale
	Date	Name	Catalog No. SD238-56-06	Size A3
Design	11/01/2017	Evgeny K.	Drawing No. SD238-56-06	Sheet 2 of 2
Check	10/01/2023	Shlomo B.		
Appr.	10/01/2023	Tzah Gr.		

RELEASED

**KRAUSZ**  
a **MUELLER** brand

Confidential Information. All rights reserved to Krausz Industries Ltd.  
This document may not be copied, reproduced, displayed,  
modified or used in any way, whether in whole or in part,  
without the express prior written consent of Krausz Industries Ltd.

