

HYMAX[®]

a **MUELLER** brand

HYMAX GRIP[®] LARGE DIAMETER* (14" - 16") Product Specifications

FEATURES

- The first restraint product of its size with only four top-facing bolts and a stab-fit, one piece design- for faster and safer installation
- Exerts gripping power equal to 55 tons on connecting pipes
- Restrains both plastic and metal pipes, including HDPE, and replaces the need to use dedicated products
- Patented grip chain offers circular restraint around the pipe
- Patented radial closing mechanism holds pipes tightly in place during installation
- Allows dynamic deflection of the pipe for up to 4° per side, reducing future pipe cracks and breaks



SPECIFICATIONS STANDARDS

- HYMAX GRIP Large Diameter meets or exceeds standards AWWA C219, NSF 61, NSF 372.

SIZE

- Available in nominal diameter from 14" - 16" standard.

MATERIALS

END RINGS

- Ductile iron casting ASTM A536 Grade 65-45-12.

CENTER RING

- Ductile iron casting ASTM A536 Grade 65-45-12.
- All product sizes with lifting eye.

*Registered Patent

GASKETS

- EPDM compounded for water and sewage in accordance with ASTM D2000, meets international standards for contact with drinking water.

GRIP CHAIN

- Gripping teeth: FN-0405 (Fe4Ni05Mo).

BRIDGE

- AISI 304 stainless steel. ASTM A240.

SPHERICAL SPACERS

- AISI 304 stainless steel. ASTM A351 CF8.

COATING

- 100% fusion bonded epoxy for enhanced corrosion protection.
- Average thickness 14 mm.
- Meet standard AWWA C116.

BOLTS, NUTS AND WASHERS

- AISI 304 stainless steel. Rolled thread and anti galling coating. ASTM F593, ASTM F594, ASTM A240 respectively.



JOIN



REPAIR



RESTRAIN



TAP

MUELLER

PRODUCT PERFORMANCE**

WORKING TEMPERATURE

- EPDM: -20° F up to +125° F

DYNAMIC DEFLECTION

- Up to 4° per side

MIN. PIPE INSERTION

- 5.9"

PRESSURES & ΔT

- ΔT - HDPE pipe expands and contracts with changes in temperature and exerts large pull-load forces on the coupling. ΔT for HDPE pipe is the change in temperature the coupling can withstand when installed on HDPE pipe.

NOTE: Insert stiffeners are required when installing this product on HDPE pipe

MAXIMUM OFFSET FOR MISALIGNED PIPES

- 0.25"

MAXIMUM OUT OF ROUNDNESS

- 0.16"

VACUUM TEST

- 12 psi

**See submittal drawings for details.

ND (inch)	Working Pressure (psi)	ΔT for HDPE SDR 9 (°F)
14	250	50
16	250	50

PRODUCT TABLES

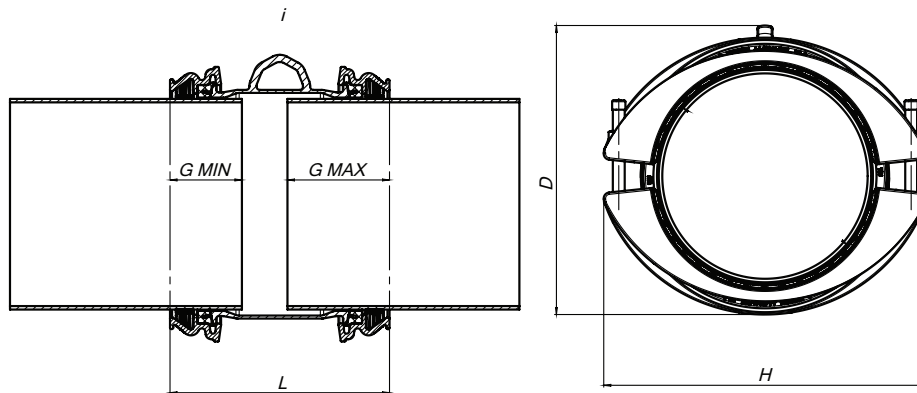

HYMAX Part Number	ND (inch)	Overall Range (inch)	L (inch)	D (inch)	H (inch)	G - Max Stab Depth (inch)	G - Min Stab Depth (inch)	Bolts Qty. - Size (inch)	Torque (ft-lbs)	Approx. Weight (lbs)
890-56-14384-17	14	15.12 - 15.75	18.6	22.2	25	8.3	5.9	4 - 1	350	224
890-56-16438-17	16	17.25 - 17.88	18.6	24.3	27.1	8.3	5.9	4 - 1	350	251

To learn more, visit HymaxUSA.com.

Mueller refers to one or more of Mueller Water Products, Inc., a Delaware corporation ("MWP"), and its subsidiaries. MWP and each of its subsidiaries are legally separate and independent entities when providing products and services. MWP does not provide products or services to third parties. MWP and each of its subsidiaries are liable only for their own acts and omissions and not those of each other. MWP brands include Mueller®, Echologics®, Hydro Gate®, Hydro-Guard®, HYMAX®, Krausz®, Jones®, Mi.Net®, Milliken®, Pratt®, Pratt Industrial®, Sentryx™, Singer®, and U.S. Pipe Valve & Hydrant. Please see muellerwp.com/brands to learn more.

© 2023 Mueller Co., LLC. All Rights Reserved. The trademarks, logos and service marks displayed in this document are the property of Mueller Co., LLC, its affiliates or other third parties. Products above marked with a section symbol (§) are subject to patents or patent applications. For details, visit www.mwppat.com. These products are intended for use in potable water applications. Please contact your HYMAX Sales or Customer Service Representative concerning any other application(s).