

HYMAX[®]

a **MUELLER** brand

HYMAX VERSA[®] ENCAPSULATION (1.5" - 6") Product Specifications

FEATURES

- A unique encapsulation solution to quickly and easily repair coupling leaks
- Fast and easy to install. Can be wrapped around joints while water pressure is lowered to avoid water shutdowns.
- Only 2 or 4 top-facing bolts to tighten
- Durable stainless steel, monoblock design
- Allows 3° dynamic deflection per side, potentially reducing future pipe damage

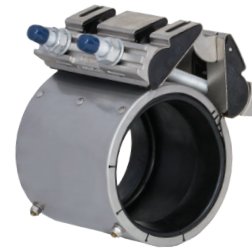

SPECIFICATIONS STANDARDS

- HYMAX VERSA Encapsulation meets or exceeds standards AWWA C-219, AWWA C-227, NSF 61, NSF 372, EN-681.

SIZE LENGTH

- Available in nominal diameter range of 1.5" - 3", length 5.5", 11".
- Nominal diameter 4" & 6" available in 11" length only.

MATERIALS

BODY

- Stainless Steel AISI 304. ASTM A240 / ASTM A480.

LUG MATERIAL

- Polycarbonate.

COMPRESSION BEAM & ADJUSTING PIN

- Casting AISI 304/ASTM-A351-CF8.

GASKET

- EPDM compounded for water and sewage in accordance with ASTM D2000, meets international standards for contact with drinking water.

GASKET BRIDGE

- Stainless Steel AISI 304. ASTM A240.

BOLTS, NUTS & WASHERS

- AISI 304 stainless steel. Rolled thread and anti-galling coating. ASTM F593, ASTM F594 and ASTM A240 respectively.



JOIN



REPAIR



RESTRAIN



TAP

MUELLER

PRODUCT PERFORMANCE

WORKING TEMPERATURE

- 20° F up to +180° F

WORKING PRESSURE

- Length 5.5": 232 psi
- Length 11": 232 psi

MAX. CAPSULE CAPABILITY

* See below

For 5.5" Length	H	W
	0.315"	2.5"
For 11" Length	H	W
	0.315"	8"

PRODUCT TABLES

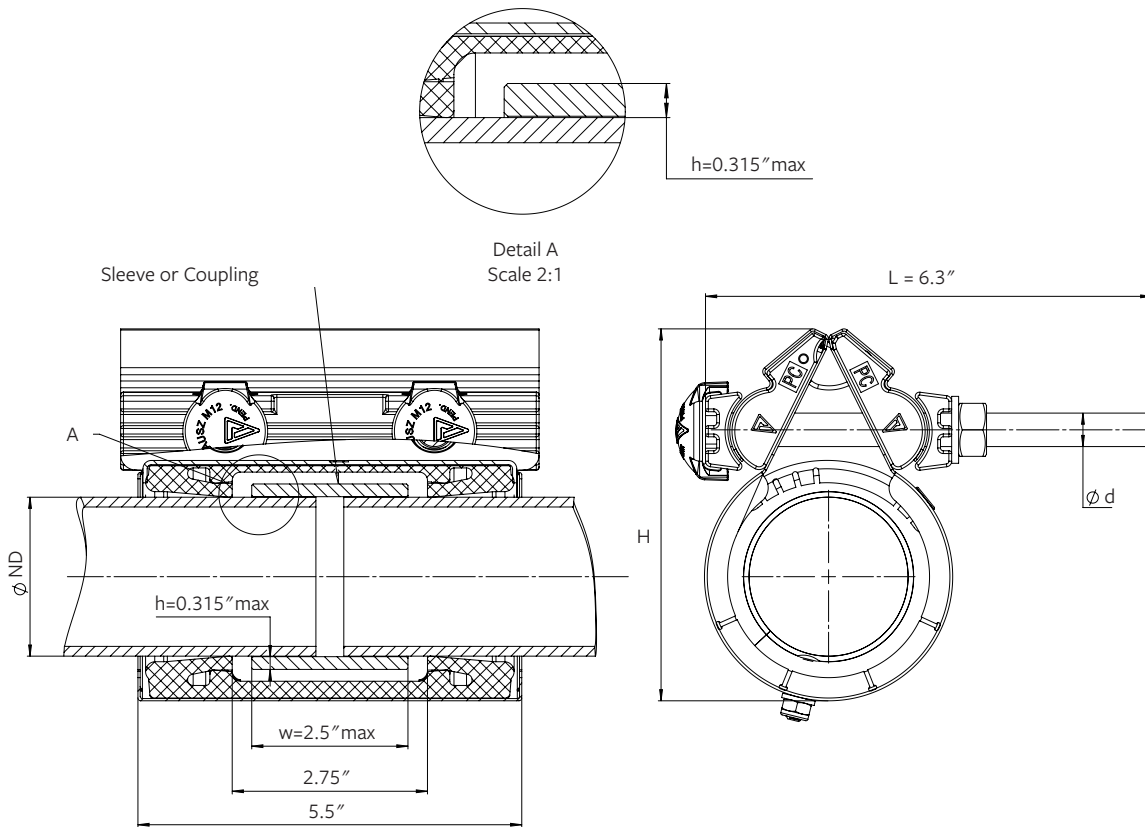

HYMAX VERSA ENCAPSULATION NOMINAL SIZE 1.5" - 3" LENGTH 5.5"

HYMAX Part Number	ND (inch)	Overall Range (inch)	H (inch)	Bolts Length L (inch)	Bolt Qty. and Size d (mm)	Torque (ft-lbs)	Body (Shell) Thickness (inch)	Approx. Weight (lbs)
104-56-0045-16	1.5	1.77 - 2.24	4.9	6.3	2 - M12	35	0.03	4.23
104-56-0052-16	2	2.05 - 2.52	5.3	6.3	2 - M12	35	0.03	4.34
104-56-0059-16-100*		2.32 - 2.79	5.5	6.3	2 - M12	35	0.03	4.5
104-56-0071-16	2.5	2.79 - 3.31	6.1	6.3	2 - M12	35	0.03	4.72
104-56-0081-16	3	3.19 - 3.67	6.5	6.3	2 - M12	35	0.03	4.83

* The product refers to PIPE IPS application explained below

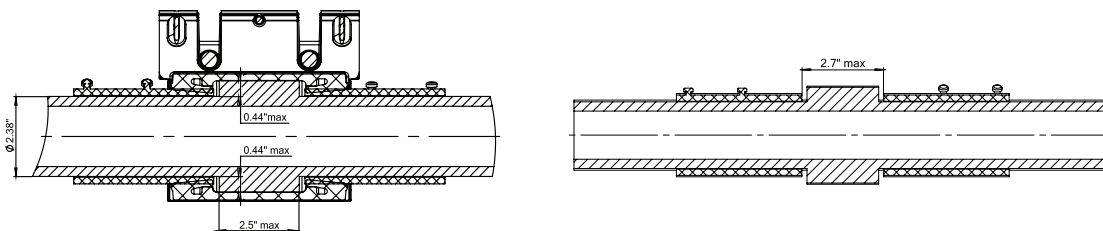

PRODUCT TABLES

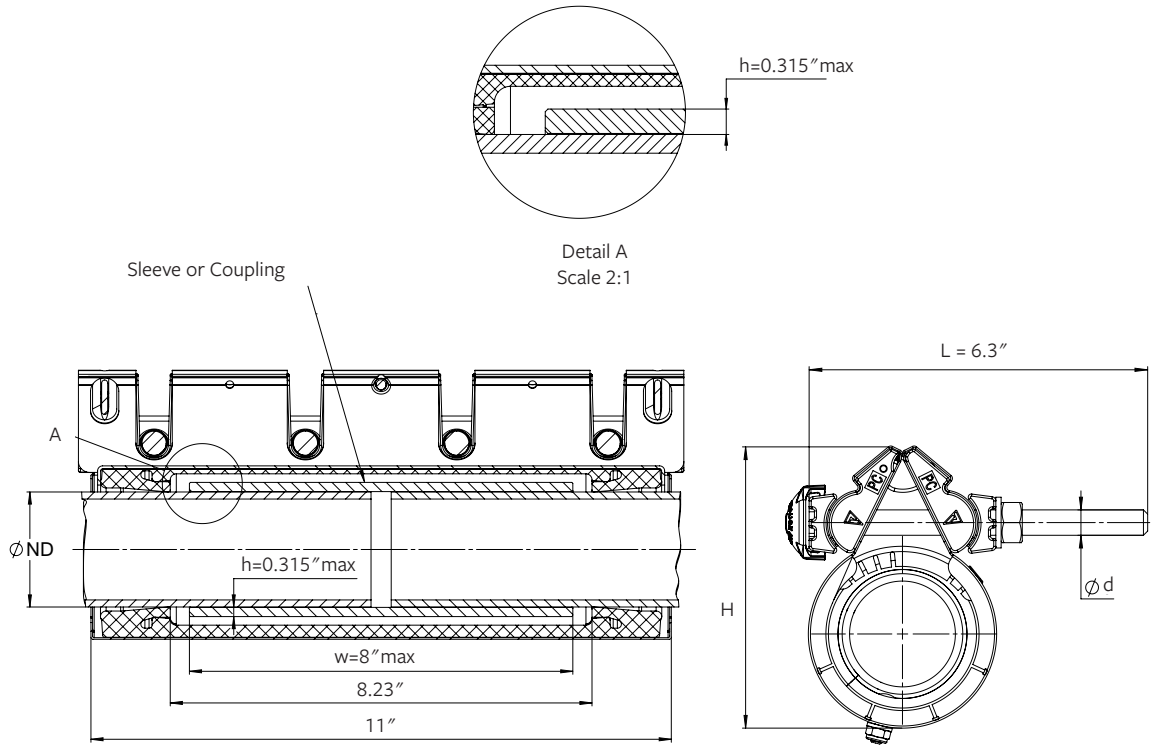

HYMAX VERSA ENCAPSULATION NOMINAL SIZE 1.5" - 3" LENGTH 11"

HYMAX Part Number	ND (inch)	Overall Range (inch)	H (inch)	Bolts Length L (inch)	Bolt Qty. and Size d (mm)	Torque (ft-lbs)	Body (Shell) Thickness (inch)	Approx. Weight (lbs)
106-56-0045-16	1.5	1.77 - 2.24	4.9	6.3	4 - M12	35	0.03	8.6
106-56-0052-16	2	2.05 - 2.52	5.3	6.3	4 - M12	35	0.03	8.82
106-56-0059-16-100*		2.32 - 2.79	5.5	6.3	4 - M12	35	0.03	9.26
106-56-0071-16	2.5	2.79 - 3.31	6.1	6.3	4 - M12	35	0.03	9.7
106-56-0081-16	3	3.19 - 3.67	6.5	6.3	4 - M12	35	0.03	9.92

* The product refers to PIPE IPS application explained below

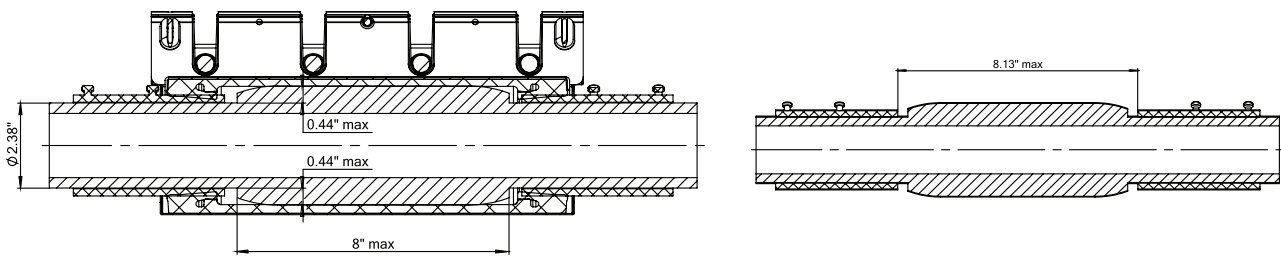

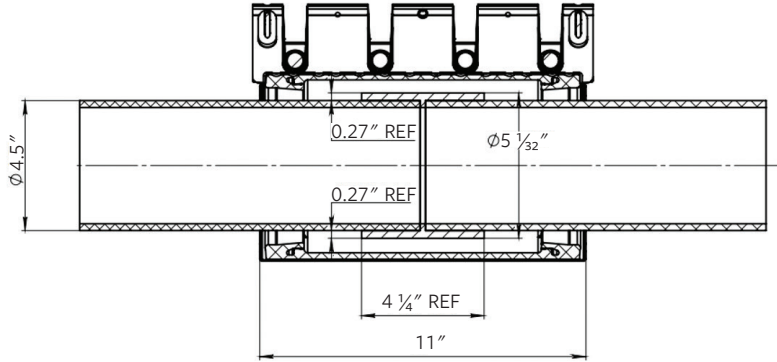
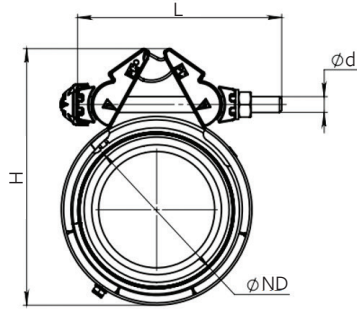

HYMAX VERSA ENCAPSULATION NOMINAL SIZE 4", LENGTH 11"

HYMAX Part Number	ND (inch)	Overall Range (inch)	H (inch)	Bolts Length (Inch)	Bolts Qty. Size d (mm)	Torque (ft-lbs)	Body (Shell) Thickness (inch)	Approx. Weight (lbs)
106-56-0113-16	4	4.50	9.0	7	4 - M14	50	0.05	16.3

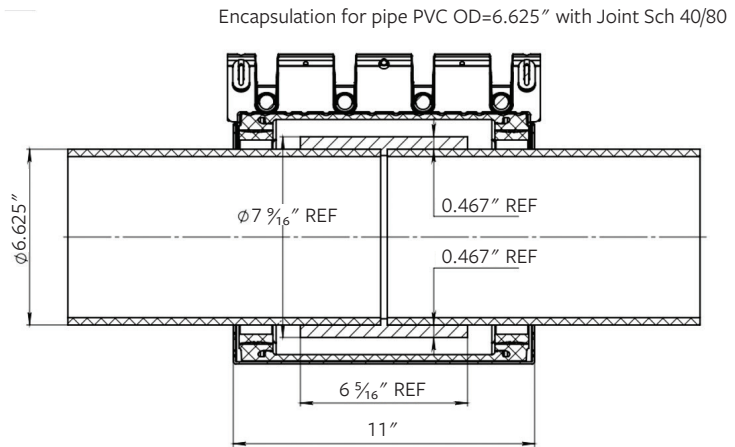
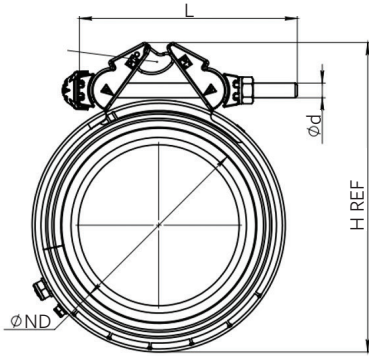

HYMAX VERSA ENCAPSULATION NOMINAL SIZE 6", LENGTH 11"

HYMAX Part Number	ND (inch)	Overall Range (inch)	H (inch)	Bolts Length (Inch)	Bolts Qty. Size d (mm)	Torque (ft-lbs)	Body (Shell) Thickness (inch)	Approx. Weight (lbs)
106-56-0163-16	6	6.63	11.6	7	4 - M14	90	0.06	24.4

To learn more, visit HymaxUSA.com.

Mueller refers to one or more of Mueller Water Products, Inc., a Delaware corporation ("MWP"), and its subsidiaries. MWP and each of its subsidiaries are legally separate and independent entities when providing products and services. MWP does not provide products or services to third parties. MWP and each of its subsidiaries are liable only for their own acts and omissions and not those of each other. MWP brands include Mueller®, Echologics®, Hydro Gate®, Hydro-Guard®, HYMAX®, Krausz®, Jones®, Mi.Net®, Milliken®, Pratt®, Pratt Industrial®, Sentryx™, Singer®, and U.S. Pipe Valve & Hydrant. Please see muellerwp.com/brands to learn more.

© 2023 Mueller Co., LLC. All Rights Reserved. The trademarks, logos and service marks displayed in this document are the property of Mueller Co., LLC, its affiliates or other third parties. Products above marked with a section symbol (§) are subject to patents or patent applications. For details, visit www.mwppat.com. These products are intended for use in potable water applications. Please contact your HYMAX Sales or Customer Service Representative concerning any other application(s).

